

# OPTIDRIVE™

## Stock Drives Catalogue

Variable Speed Drives  
& Accessories



# Company Overview



UK Headquarters  
Welshpool

## Inverter Drives

**Inverter Drives** is dedicated to the design and manufacture of sophisticated electronic variable speed drives, used to control motors in a wide variety of industrial and energy saving applications.

## The Organisation

State of the art UK headquarters house specialist facilities for innovation, manufacturing and global marketing.

The company pledges to implement and operate the ISO 14001 Environmental Management System to enhance environmental performance.

All operations, including innovation, are accredited to the exacting customer focused ISO 9001 quality standard.

The company's products are sold globally by a network of specialist distributors in over 80 different countries. Inverter Drives' unique and innovative Optidrive range is designed for ease of use and meets recognised international design standards for CE (Europe), UL (USA) and CTick (Australia).



## Innovative Products

- Easy to use variable speed drives
- Incredible performance
- Robust & reliable
- Low cost of installation & ownership
- Wide power range  
0.37–250kW, 115V–600V



Global sales, service & application support network **in over 80 countries**

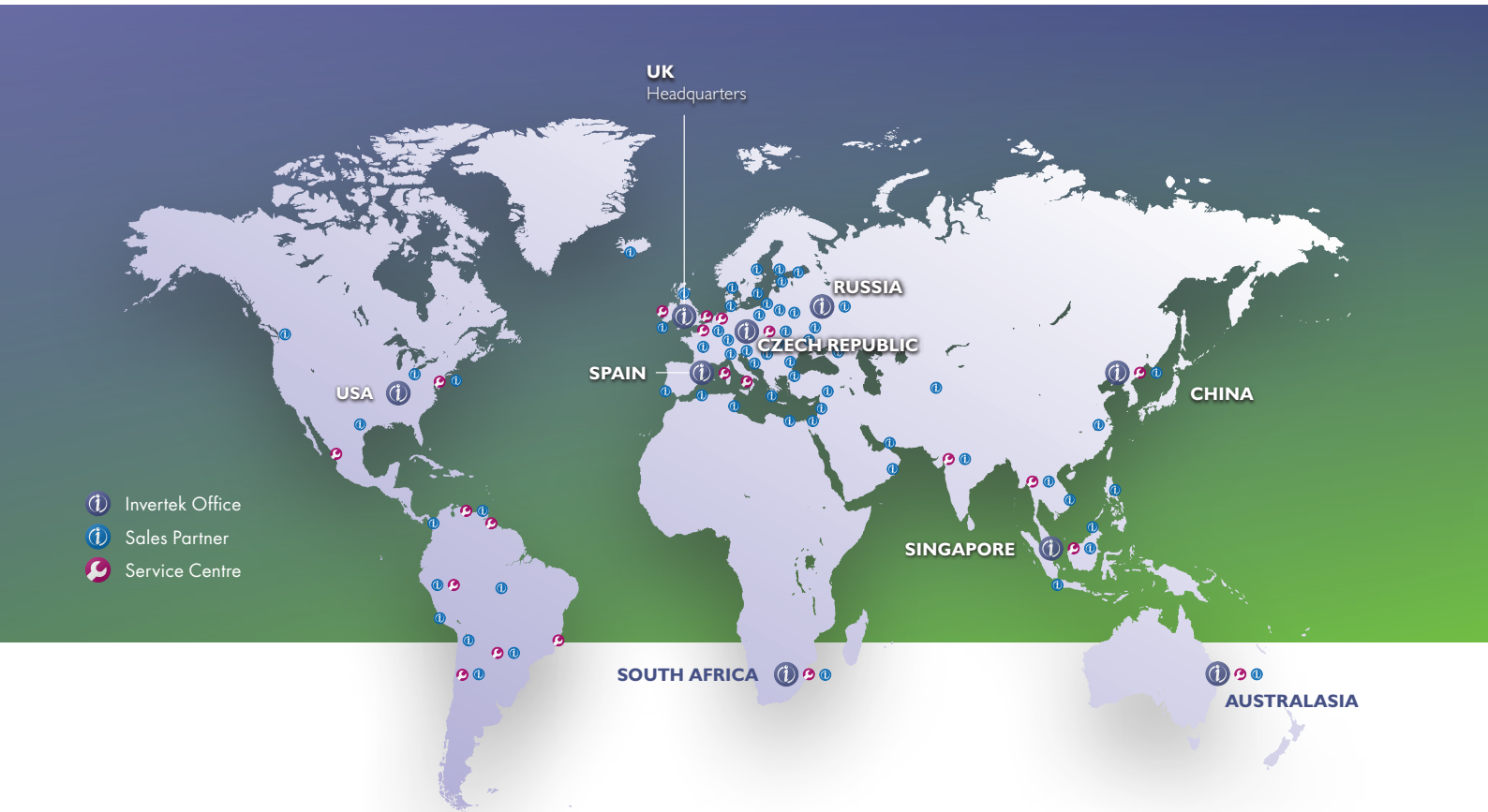

Online Support    Pre-sales Support    Customer Service    Technical Support    Knowledge Management    Field Service    Logistics & Distribution    Spare Parts & Repair    Service Contracts    International Support



- Conveyors
- HVAC
- Machine Tools



- Manufacturing
- Pumping
- Process Control



- Elevators
- Cranes







Pages 2-7

Pages 8-11

Page	AC Variable Speed Drives
2	<b>OPTIDRIVE P2</b>
8	<b>OPTIDRIVE E2</b>
12	<b>OPTIDRIVE E2</b> Single Phase
14	<b>OPTIDRIVE HVAC Eco</b>
20	<b>OPTIDRIVE HVAC</b>
24	<b>OPTIDRIVE PCE</b>

### Options

26	Keypads & Displays
27	Plug-in Options
28	Software / Commissioning
29	Networking Options
30	Input Chokes
31	Output Chokes
32	EMC Filters
33	Brake Resistors
34	Mains Isolators
34	Through Hole Mount Kits
35	Options Compatibility

Product Range	P2	E2
Previous Optidrive Version	Optidrive Plus	Optidrive E & EF
<b>IP20</b> Supply / Power Range	200-240V, 1ph, 4.3 to 10.5A (0.75 to 2.2kW / 1.0 to 3.0HP) 200-240V, 3ph, 4.3 to 24A (0.75 to 5.5kW / 1.0 to 7.5HP) 380-480V, 3ph, 2.2 to 24A (0.75 to 11kW / 1.0 to 15HP) 500-600V, 3ph, 2.1 to 22A (0.75 to 15kW / 1.0 to 20HP)	110-115V, 1ph, 2.3 to 5.8A (0.5 to 1.5HP) 200-240V, 1ph, 2.3 to 15A (0.37 to 4kW / 0.5 to 5HP) 200-240V, 3ph, 2.3 to 18A (0.37 to 4kW / 0.5 to 5HP) 380-480V, 3ph, 2.2 to 24A (0.75 to 11kW / 1.0 to 15HP)
<b>IP55</b> Supply / Power Range	200-240V, 3ph, 24 to 248A (5.5 to 75kW / 7.5 to 100HP) 380-480V, 3ph, 24 to 302A (11 to 160kW / 15 to 250HP) 480-525V, 3ph, 185 to 275A (132 to 200kW) 500-600V, 3ph, 22 to 150A (15 to 110kW / 20 to 150HP)	110-115V, 1ph, 2.3 to 5.8A (0.5 to 1.5HP) 200-240V, 1ph, 2.3 to 10.5A (0.37 to 2.2kW / 0.5 to 3HP) 200-240V, 3ph, 2.3 to 18A (0.37 to 4kW / 0.5 to 5HP) 380-480V, 3ph, 2.2 to 18A (0.75 to 7.5kW / 1.0 to 10HP)
<b>IP66</b> Supply / Power Range	200-240V, 1ph, 4.3 to 10.5A (0.75 to 2.2kW / 1.0 to 3.0HP) 200-240V, 3ph, 4.3 to 18A (0.75 to 4.0kW / 1.0 to 5HP) 380-480V, 3ph, 2.2 to 18A (0.75 to 7.5kW / 1.0 to 10HP) 500-600V, 3ph, 2.1 to 17A (0.75 to 11kW / 1.0 to 15HP)	110-115V, 1ph, 2.3 to 5.8A (0.5 to 1.5HP) 200-240V, 1ph, 2.3 to 15A (0.37 to 4kW / 0.5 to 5HP) 200-240V, 3ph, 2.3 to 18A (0.37 to 4kW / 0.5 to 5HP) 380-480V, 3ph, 2.2 to 18A (0.75 to 7.5kW / 1.0 to 10HP)
Operating Ambient Rating	-10 to 50°C	Up to 50°C
<b>Control Modes</b>	V/F, Energy Optimised, Sensorless & Closed Loop Vector, Open Loop Permanent Magnet	V/F Energy Optimised
Maximum Output Hz Linear / Variable Torque Control	500 Linear	500 Linear
Motor Overload Capacity	150% - 60 Secs 200% - 3.75 Secs 250% - 1.8 Secs 300% (max) - 1.25 Secs	150% - 60 Secs 175% - 2 Secs
Internal EMC Filter Unit Available	All models provided with internal EMC filter	Optional, refer to product page
Internal Brake Transistor	Standard Frame Sizes 2-5 Optional Frame Sizes 6 and above	Frame Sizes 2-3
I/O Connections	3 x Programmable Digital Inputs 2 x User-selectable Digital or Analog Inputs 2 x User-selectable Digital or Analog Outputs 2 x Programmable Relays (1 x change-over, 1 x single pole) Safe Torque Off inputs	2 x Programmable Digital Inputs 2 x User-selectable Digital or Analog Inputs 1 x User-selectable Digital or Analog Output 1 x Programmable Relay (single pole)
Factory Fit Controls (Speed Potentiometer, FWD - 0 - REV, Power Isolator)	Optional on IP66 Models	Optional on IP66 Models
Pulse Frequency Speed Reference	Yes - Digital Input 3 (20kHz Max)	No
Power Supplies	24VDC @ 100mA 10VDC @ 10mA (for potentiometer)	24VDC @ 100mA 10VDC @ 10mA (for potentiometer)
Display Type	IP20: 7 Segment LED IP55 & IP66: Optional 7 Segment LED or OLED	7 Segment LED
Keypad	7-Seg = 5 Buttons (start, stop, navigate, up, down) OLED = 5 Buttons (start, stop, navigate, up, down)	5 Buttons (start, stop, navigate, up, down)
Service/Maintenance Indication	Yes	No
PI / PID Control	Yes [PID]	Yes [PI]
Energy Optimiser	Yes	Yes
Spin Start	Yes	Yes, Frames 2-3
Safe Torque Off Function	Yes	No
Pluggable Terminals	Yes	No
Fire Mode	No	No
Pump Cascade	No	No
Mains Power Disconnect	IP55: External Option IP66: Factory Fit Option	IP66: Factory Fit Option
Bluetooth	Yes [Requires Optistick]	Yes [Requires Optistick]
Parameter Copy Module	Optistick	Optistick
Communications	Modbus RTU, CANopen onboard PROFIBUS, DeviceNet, EtherNet/IP, Modbus TCP, PROFINET, EtherCAT with plug in interface	Modbus RTU on board PROFIBUS, DeviceNet or EtherNet/IP via external gateway
PC Software	OptiTools Studio	Optistore V3 OptiTools Studio
Simple PLC Functionality	Licensed Software Tool	No
Remote Keypad	OPT-2-OPORT-IN, OPT-2-OPPAD-IN, OPT-2-OPDKT-IN	OPT-2-OPORT-IN, OPT-2-OPPAD-IN, OPT-2-OPDKT-IN
Options	OPT-2-CASCD-IN OPT-2-ENCOD-IN OPT-2-EXTIO-IN OPT-2-PROFB-IN OPT-2-ETHNT-IN OPT-2-DEVNT-IN	OPT-HVACO-IN ODP-2ROUT-IN OPT-LOGIP-11-IN OPT-LOGIP-23-IN
Conformance	CE, UL, cUL, C-Tick, RoHS, GOST R	CE, UL, cUL, C-Tick, GOST



Easy to use, reliable products  
with incredible performance





Pages 12–13



Pages 14–19



Pages 20–23

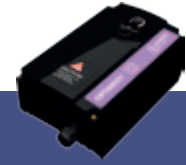

Pages 24–25

E2 Single Phase	HVAC Eco	HVAC	PCE
Optidrive E1 & EF1	Optidrive VTC & HVAC	Optidrive VTC	None
110–115V, 1ph, 7 to 10.5A (0.5 to 0.75HP) 200–240V, 1ph, 4.3 to 10.5A (0.37 to 1.1kW / 0.5 to 1.5HP)		200–240V, 1ph, 4.3 to 10.5A (0.75 to 2.2kW / 1.0 to 3.0HP) 200–240V, 3ph, 4.3 to 24A (0.75 to 5.5kW / 1 to 7.5HP) 380–480V, 3ph, 2.2 to 24A (0.75–1.1kW / 1.0 to 15HP) 500–600V, 3ph, 2.1 to 22A (0.75 to 15kW / 1.0 to 20HP)	
110–115V, 1ph, 7 to 10.5A (0.5 to 0.75HP) 200–240V, 1ph, 4.3 to 10.5A (0.37 to 1.1kW / 0.5 to 1.5HP)	380–480V, 3ph, 30 to 90A (15.45kW / 20 to 60HP)	200–240V, 3ph, 24 to 248A (5.5 to 75kW / 7.5 to 100HP) 380–480V, 3ph, 24 to 302A (11 to 160kW / 15 to 250HP) 480–525V, 3ph, 185 to 275A (132 to 200kW) 500–600V, 3ph, 22 to 150A (15 to 110kW / 20 to 150HP)	200–240V, 1ph, 4.5 to 7A (0.75 to 1.5kW / 1 to 2HP) 380–480V, 3ph, 2.2 to 4.1A (0.75 to 1.5kW / 1 to 2HP)
110–115V, 1ph, 7 to 10.5A (0.5 to 0.75HP) 200–240V, 1ph, 4.3 to 10.5A (0.37 to 1.1kW / 0.5 to 1.5HP)	380–480V, 3ph, 2.2 to 24A (0.75–1.1kW / 1 to 15HP)	200–240V, 1ph, 4.3 to 10.5A (0.75 to 2.2kW / 1.0 to 3.0HP) 200–240V, 3ph, 4.3 to 18A (0.75 to 4.0kW / 1.0 to 5HP) 380–480V, 3ph, 2.2 to 18A (0.75 to 7.5kW / 1.0 to 10HP) 500–600V, 3ph, 2.1 to 17A (0.75 to 11kW / 1.0 to 15HP)	
Up to 50°C	–10 to 50°C	–10 to 50°C	Up to 40°C
V/F	Sensorless Vector CT / VT	V/F Energy Optimised	V/F, Energy Optimised, Sensorless Vector
120	500	120	500
Linear	Linear & Variable	Linear & Variable	Linear
150% - 60 Secs 175% - 2 Secs	110% - 60 Secs 125% - 7.5 Secs 150% - 4 Secs 165% - 3 Secs	110% - 60 Secs 125% - 7.5 Secs 150% - 3.9 Secs 165% (max) - 2.9 Secs	150% - 60 Secs 175% - 2 Secs
110V not available with filter All other models available with or without filter	All models provided with internal EMC filter	All models provided with internal EMC filter	All models available with or without filter
Frame Size 2 Only	Not Available	Not Available	No
2 x Programmable Digital Inputs 2 x User-selectable Digital or Analog Inputs 1 x User-selectable Digital or Analog Output 1 x Programmable Relay (single pole)	3 x Programmable Digital Inputs 2 x User-selectable Digital or Analog Inputs 2 x User-selectable Digital or Analog Outputs 2 x Programmable Relays (1 x change-over, 1 x single pole) Safe Torque Off inputs	3 x Programmable Digital Inputs 2 x User-selectable Digital or Analog Inputs 2 x User-selectable Digital or Analog Outputs 2 x Programmable Relays (1 x change-over, 1 x single pole) Safe Torque Off inputs	2 x Programmable Digital Inputs 2 x User-selectable Digital or Analog Inputs 1 x Programmable Relay (single pole)
Optional on IP66 Models Note: Reverse motor rotation is not possible	Optional on IP66 Models	Optional on IP66 Models	Optional Factory Fit
No	No	No	No
24VDC @ 100mA 10VDC @ 10mA (for potentiometer)	24VDC @ 100mA 10VDC @ 10mA (for potentiometer)	24VDC @ 100mA 10VDC @ 10mA (for potentiometer)	24VDC @ 100mA
7 Segment LED	OLED	IP20: 7 Segment LED IP55 & IP66: OLED	None
5 Buttons (start, stop, navigate, up, down)	7 Buttons (start, stop, navigate, up, down, hand, auto)	7-Seg = 5 Buttons (start, stop, navigate, up, down) OLED = 7 Button (start, stop, navigate, up, down, hand, auto)	Optional Remote
No	Yes	Yes	No
Yes (PI)	Yes (PID)	Yes (PID)	Yes (PID)
No	Yes	Yes	Yes
No	Yes	Yes	Yes
No	Yes	Yes	No
No	Yes	Yes	Yes
No	Yes	Yes	No
No	Yes	Yes	No
IP66: Factory Fit Option	IP55: External Option IP66: Factory Fit Option	IP55: External Option IP66: Factory Fit Option	No
Yes (Requires Optistick)	Yes (Requires Optistick)	Yes (Requires Optistick)	No
Optistick	Optistick	Optistick	No
Modbus RTU on board PROFIBUS, DeviceNet, EtherNet/IP via external gateway	Modbus RT, BACnet MS/TP on board BACnet IP, Modbus TCP, EtherNet/IP, PROFIBUS, PROFINET, DeviceNet, EtherCAT optional plug in interface	Modbus RT, BACnet MS/TP on board BACnet IP, Modbus TCP, EtherNet/IP, PROFIBUS, PROFINET, DeviceNet, EtherCAT optional plug in interface	No
OptiTools Studio	OptiTools Studio	OptiTools Studio	Optistore V3
No	Licensed Software Tool	Licensed Software Tool	No
OPT-2-OPORT-IN, OPT-2-OPPAD-IN, OPT-2-OPDKT-IN	OPT-2-OPORT-IN, OPT-2-OPPAD-IN, OPT-2-OPDKT-IN	OPT-2-OPORT-IN, OPT-2-OPPAD-IN, OPT-2-OPDKT-IN	OD-OPRTP
OPT-HVACO-IN ODP-2ROUT-IN OPT-LOGIP-11-IN OPT-LOGIP-23-IN	OPT-2-CASCD-IN OPT-2-EXTIO-IN OPT-2-BACNT-IN OPT-2-PROFB-IN OPT-2-ETHNT-IN OPT-2-DEVNT-IN	OPT-2-CASCD-IN OPT-2-EXTIO-IN OPT-2-BACNT-IN OPT-2-PROFB-IN OPT-2-ETHNT-IN OPT-2-DEVNT-IN	None Available
CE, UL, cUL, C-Tick, GOST	CE, UL, cUL, C-Tick	CE, UL, cUL, C-Tick	CE, UL, cUL, C-Tick, GOST

Global service and support network  
Leading edge design & technology

# OPTIDRIVE™ CP<sup>2</sup>

AC Variable Speed Drive

0.75 – 250kW / 1 – 350HP  
200 – 480V Single & 3 Phase Input

## World Leading Motor Control

Controlling the latest generation of permanent magnet motors and standard induction motors

Optidrive P2 offers the perfect combination of high performance together with ease of use to allow even the most demanding applications to be tackled easily.

- Low ambient operation (–10°C)
- Dedicated Hoist Mode
- CAN and Modbus RTU communication as standard

### High Performance

#### Sensorless Vector Control

Up to 200% torque from zero speed ensures reliable starting and accurate speed control under all load conditions.

#### PM Motor Control

Future proof. Allows upgrade to the latest generation of high efficiency permanent magnet motors.

#### I/O & Communications

Optidrive P2 supports a wide range of interfaces to machine control systems.

### Low Cost Installation

#### Built-in EMC Filter

An internal filter in every Optidrive P2 saves cost and time for installation.

#### Integral Brake Transistor

Saves space, cost and time for installation.

### Powerful PC based commissioning software

## OptiTools Studio

OptiTools Studio allows parameter upload, download and storage and access to Optidrive P2 Simple PLC functionality.

See Page 28

### OPTISTICK

Product Code: OPT-2-STICK-IN



 Bluetooth®

- Fast parameter copying between drives
- Bluetooth PC interface for OptiTools Studio commissioning software



IP55 / NEMA 12

Up to 200kW



IP66 / NEMA 4X

Up to 7.5kW

Manufacturing **Conveyer Systems** **Plastics** **Processing Plants** **Chemical**  
**Pumping** **Machine Tools** **Rubber** **Elevators** **Cranes**

150% overload for 60 seconds

200% overload for 4 seconds

Industrial heavy duty rating for every model



**Convenient  
Help Card**



**Optional LED or OLED  
(IP55 & IP66)**

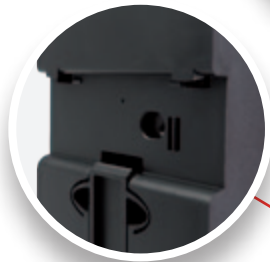

**DIN Rail Mount  
(IP20)**



**Pluggable  
Terminals**



**High Quality  
Long-life Fans**





**Simple PLC Functionality**

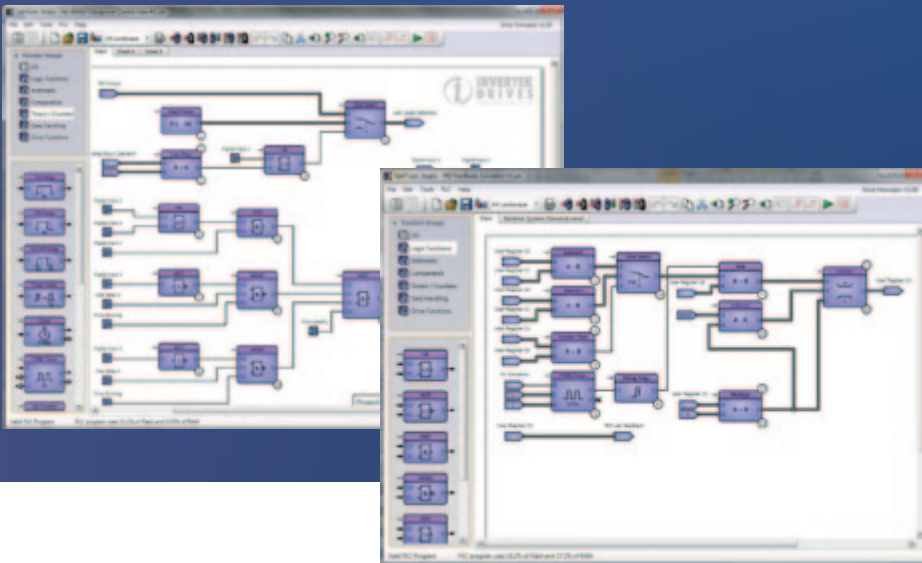

A wide range of function types available including:

- Programmable Logic Functions
- Comparators
- Timers
- Mathematical Functions
- Drive specific functions

All blocks can be easily combined to create flexible programs.

Programs can be protected to prevent unauthorised copying.

Complete control over the drive including all inputs and outputs.

**Safe Torque Off (provided as standard)**

Optidrive P2 features a safe torque off function to allow simple integration into machine critical safety circuits.

- Simple machine design reduces component costs, saves panel space and minimises installation time
- Faster shut down and reset procedures reduce system maintenance time
- Better safety standard compared to mechanical solution
- Better motor connection. Single cable with no interruption.



**With**

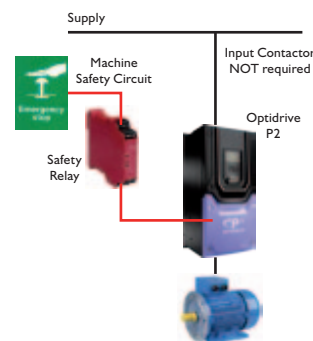

**Without**

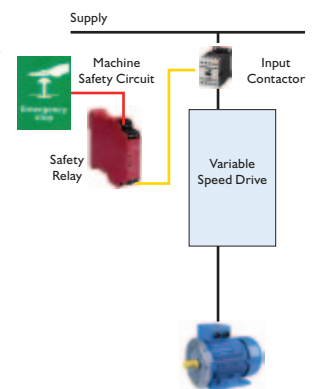



### IP20

Panel mount units available up to 11kW



### IP55

Wall mount units available up to 200kW



### IP66

Wall mount units available up to 7.5kW

## Advanced Motor Control

Optidrive P2 has been uniquely developed to allow a wide range of different motor types to be used, with only parameter changes being required. This technology allows the same drive to be used in a wide range of applications, allowing OEM's and end user alike to take advantage of the energy saving provided by using the latest motor technologies.

### AC Induction Motors

The majority of AC motors in use today around the world are standard induction motors. These motors are relatively low cost, readily available and provide good performance with long service life. With the ever increasing focus on energy efficiency, motor manufacturers have refined and improved their designs in recent years.

Optidrive P2 has been developed to provide optimum control and maximum efficiency when operating with older motors designs, or newer high efficiency designs.

Operation can be in simple V/F control mode or in High Performance Third Generation Vector Mode, which provides up to 200% torque from zero speed without requiring an encoder.

### Permanent Magnet AC Motors

Permanent magnet AC motors provide improved efficiency compared to standard induction motors. Using permanent magnets in the motor construction eliminates the need for any magnetising current, reducing electrical losses. PM motors have been used for many years in high performance applications, however this has always required the use of a feedback device, such as a resolver or encoder. Optidrive P2 has been designed to operate with AC PM motors without requiring any feedback device, allowing them to be used for their energy efficiency benefits without incurring extra cost and complexity in applications which do not require position feedback.

### Brushless DC Motors

BLDC motors are similar to AC PM motors, however the design requires a slightly different control method to optimise the performance. Optidrive P2 has the flexibility to control this type of motor, requiring only simple parameter changes. This provides much greater flexibility for OEM's, allowing Optidrive P2 to be used in a variety of applications, with various motor types.

### Synchronous Reluctance Motors

Synchronous Reluctance Motors (SynRM), not to be confused with Switched Reluctance Motors, share a similar stator construction to standard induction motors, however the rotor is substantially different, in order to improve the overall efficiency of the motor. SynRM motors are ideally suited to variable torque applications.

Optidrive P2 can control synchronous reluctance motors, allowing the energy saving benefits to be realised.





## Drive Specification

Input Ratings	Supply Voltage	200 – 240V ± 10% 380 – 480V ± 10% 480 – 525V ± 10% 500 – 600V ± 10%	
	Supply Frequency	48 – 62Hz	
	Displacement Power Factor	> 0.98	
	Phase Imbalance	3% Maximum allowed	
	Inrush Current	< rated current	
	Power Cycles	120 per hour maximum, evenly spaced	
	Output Ratings	Output Power	230V 1 Phase: 0.75–2.2kW / 1–3HP 230V 3 Phase: 0.75–7.5kW / 1–100HP 400V 3 Phase: 0.75–250kW 460V 3 Phase: 1–350HP 525V 3 Phase: 0.75–200kW 575V 3 Phase: 0.75–110kW / 1–150HP
Overload Capacity		150% for 60 seconds	
Output Frequency		0 – 500Hz, 0.1Hz resolution	
Typical Efficiency		98%	
Ambient Conditions		Temperature: Storage: –40 to 60°C Operating: –10 to 50°C Altitude: Up to 1000m ASL without derating Up to 2000m maximum UL Approved Up to 4000m maximum (non UL) Above 1000m: Derate by 1% per 100m Humidity: 95% Max, non-condensing	
Programming	Keypad	Built-in keypad as standard Optional remote mountable keypad	
	Display	Optional OLED or LED display (OLED Display Multi Language)	
	PC	OptiTools Studio	
Control Specification	Control Method	V/F Voltage Vector Energy Optimised V/F Sensorless Vector Speed Control Sensorless Vector Torque Control Synchronous Reluctance Motor Control Brushless DC Motor Control Closed Loop [Encoder] Speed Control Closed Loop [Encoder] Torque Control Open Loop PM Vector Control	
	PWM Frequency	4–32kHz Effective	
	Stopping Mode	Ramp to Stop: User Adjustable 0.1–600 secs Coast to Stop	
	Braking	Motor Flux Braking Built-in Braking Transistor (Optional for frame sizes 6, 7 & 8)	
	Skip Frequency	Single point, user adjustable	
	Setpoint Control	Analog Signal	0 to 10 Volts 10 to 0 Volts –10 to 10 Volts 0 to 20mA 20 to 0mA 4 to 20mA 20 to 4mA
		Digital	Motorised Potentiometer (Keypad) Modbus RTU CANopen
		Optional	PROFIBUS DP, DeviceNet, EtherNet/IP, Modbus TCP, EtherCAT, PROFINET

I/O Specification	Power Supply	24 Volt DC, 100mA, Short Circuit Protected 10 Volt DC, 5mA for Potentiometer
	Programmable Inputs	5 Total as standard (Optional additional 3) 3 Digital (Optional additional 3) 2 Analog / Digital Selectable
	Digital Inputs	10 – 30 Volt DC, internal or external supply, PNP Response time: < 4ms
	Analog Inputs	Resolution: 12 bits Response time: < 4ms Accuracy: < ± 2% of Full Scale Parameter adjustable scaling and offset
	Programmable Outputs	4 Total (Optional additional 3) 2 Analog / Digital 2 Relays (Optional additional 3)
Relay Outputs	Relay Outputs	Maximum Voltage: 250 VAC, 30 VDC Switching Current Capacity: 6A AC
	Analog Outputs	0 to 10 Volt 0 to 20mA 4 to 20mA
	Control Features	Hoist Operation: Dedicated Hoist Operation Mode PID Control: Internal PID control with feedback display
Maintenance & Diagnostics	Fault Memory	Last 4 Trips stored with time stamp
	Data Logging	Logging of data prior to trip for diagnostic purposes: Output Current, Drive Temperature, DC Bus Voltage
	Maintenance Indicator	Maintenance Indicator with user adjustable maintenance interval Onboard service life monitoring
	Monitoring	Hours Run Meter Resettable & Non Resettable kWh meters
Design Standards	EN 61800-3:2004	Adjustable speed electrical power drive systems. EMC requirements.
	2004/108/EC	
	Low Voltage Directive	230V 1 Phase Models Category C1 according to EN61800-3:2004
	Machinery Directive	400V 3 Phase Models Category C2 according to EN61800-3:2004
	Safe Torque Off Function	Cat 3 / PL "d" According to ISO 13849-1
	Conformance	SIL CL2 According to EN61800-5-2 / EN62061 / IEC61508 CE, UL, cUL, C-Tick, RoHS, GOST R IP20 (Size 2, 3, 8) IP55 (Size 4, 5, 6, 7) IP66 (Size 2, 3; up to 7.5kW)

## Model Code Guide

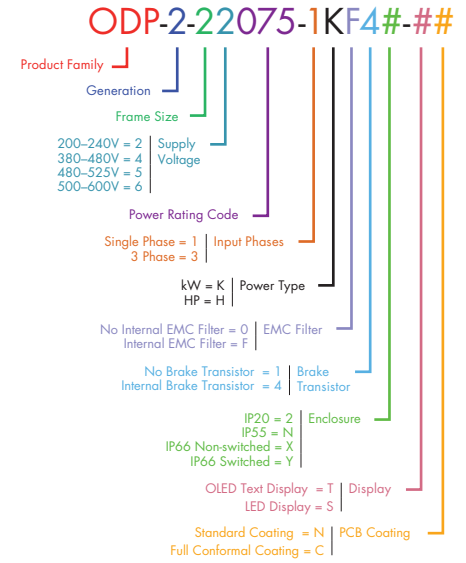

## Connection Diagram

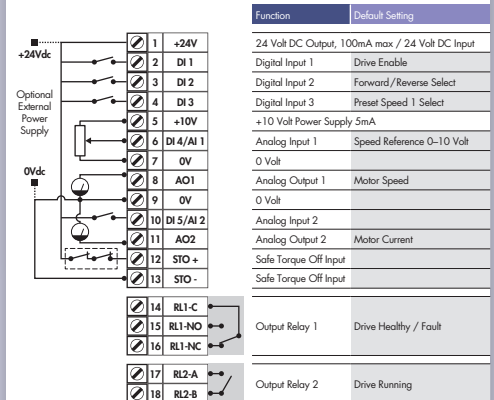

NOT TO SCALE



Size	IP20		IP66		IP55			IP20
	2	3	2	3	4	5	6	8
mm Height	221	261	257	310	440	540	865	1005
mm Width	110	131	188	211	171	235	330	480
mm Depth	185	205	239	266	252	270	330	480
kg Weight	1.8	3.5	4.8	7.3	11.5	22.5	50	200

## General Purpose

Dedicated to low power applications, Optidrive E2 combines innovative technology, reliability, robustness and ease of use in a range of compact IP20 & IP66 enclosures

### Key Features

- ✓ **Intuitive Keypad Control**  
Precise digital control at the touch of a button.
- ✓ **Simple Commissioning**  
14 parameter basic setup. Default settings suitable for most applications. Contactor style connection for simple wiring.
- ✓ **Integral RFI Filter**  
Options for built-in and external filters for full EMC compliance.
- ✓ **Modbus RTU**  
Easy integration with your control & monitoring systems.
- ✓ **Compact Enclosures**  
Small mechanical envelopes to help minimise your space requirements.
- ✓ **Brake Chopper (Sizes 2 & 3)**  
Dynamic & compact options with heatsink mounted resistor.
- ✓ **High Overload Capability**  
150% overload for 60 seconds.  
175% overload for 2 seconds.
- ✓ **Industrial Ambient Ratings**  
Up to 50°C operation



Bottling Pumping Processing Plants HVAC Baggage Handling Chemical Woodworking Agricultural Mining Conveyor Systems

**IP20**

Available up to 11kW

**IP66**

Available up to 7.5kW



**Convenient  
Help Card**



**EMC & Varistor  
Disconnect**



**Optistick  
Programming**



**DIN Rail Mount**



**Optional Braking  
Resistor**





kW	HP	Amps	Size	kW Model Code							HP Model Code							Factory Build Options											
				Product Range	Generation	Frame Size	Supply Voltage	Power Rating	Input Phases	Power Type	Product Range	Generation	Frame Size	Supply Voltage	Power Rating	Input Phases	Power Type	EMC Filter	Low Voltage Filter	High Voltage Filter	No EMC Filter	Brake Transistor	No Internal Brake Transistor	Internal Brake Transistor	Enclosure	IP20	IP66 Non-switched	IP66 Switched	
110-115V ± 10% (230V 3 Phase Output) 1 Phase Input	-	0.5	2.3	1	N/A							ODE - 2 - 1 1 005 - 1 H 0 1 #											0	1			2	X	Y
	-	1	4.3	1	N/A							ODE - 2 - 1 1 010 - 1 H 0 1 #											0	1			2	X	Y
	-	1.5	5.8	2	N/A							ODE - 2 - 2 1 015 - 1 H 0 4 #											0	4			2	X	Y
200-240V ± 10% 1 Phase Input	0.37	0.5	2.3	1	ODE - 2 - 1 2 037 - 1 K # 1 #							ODE - 2 - 1 2 005 - 1 H # 1 #							B	0			1				2	X	Y
	0.75	1	4.3	1	ODE - 2 - 1 2 075 - 1 K # 1 #							ODE - 2 - 1 2 010 - 1 H # 1 #							B	0			1				2	X	Y
	1.5	2	7	1	ODE - 2 - 1 2 075 - 1 K # 1 #							ODE - 2 - 1 2 011 - 1 H # 1 #							B	0			1				2	X	Y
	1.5	2	7	2	ODE - 2 - 2 2 150 - 1 K # 4 #							ODE - 2 - 2 2 020 - 1 H # 4 #							B	0			4				2	X	Y
	2.2	3	10.5	2	ODE - 2 - 2 2 220 - 1 K # 4 #							ODE - 2 - 2 2 030 - 1 H # 4 #							B	0			4				2	X	Y
	4	5	15	3	ODE - 2 - 3 2 040 - 1 K 0 4 #							ODE - 2 - 3 2 050 - 1 H 0 4 #							B	0			4				2	X	Y
200-240V ± 10% 3 Phase Input	0.37	0.5	2.3	1	ODE - 2 - 1 2 037 - 3 K # 1 #							ODE - 2 - 1 2 005 - 3 H # 1 #							B	0			1				2	X	Y
	0.75	1	4.3	1	ODE - 2 - 1 2 075 - 3 K # 1 #							ODE - 2 - 1 2 010 - 3 H # 1 #							B	0			1				2	X	Y
	1.5	2	7	1	ODE - 2 - 1 2 150 - 3 K # 1 #							ODE - 2 - 1 2 020 - 3 H # 1 #							B	0			1				2	X	Y
	1.5	2	7	2	ODE - 2 - 2 2 150 - 3 K # 4 #							ODE - 2 - 2 2 020 - 3 H # 4 #							B	0			4				2	X	Y
	2.2	3	10.5	2	ODE - 2 - 2 2 220 - 3 K # 4 #							ODE - 2 - 2 2 030 - 3 H # 4 #							B	0			4				2	X	Y
	4	5	18	3	ODE - 2 - 3 2 040 - 3 K # 4 #							ODE - 2 - 3 2 050 - 3 H # 4 #							B	0			4				2	X	Y
380-480V ± 10% 3 Phase Input	0.75	1	2.2	1	ODE - 2 - 1 4 075 - 3 K # 1 #							ODE - 2 - 1 4 010 - 3 H # 1 #							A	0			1				2	X	Y
	1.5	2	4.1	1	ODE - 2 - 1 4 150 - 3 K # 1 #							ODE - 2 - 1 4 020 - 3 H # 1 #							A	0			1				2	X	Y
	1.5	2	4.1	2	ODE - 2 - 2 4 150 - 3 K # 4 #							ODE - 2 - 2 4 020 - 3 H # 4 #							A	0			4				2	X	Y
	2.2	3	5.8	2	ODE - 2 - 2 4 220 - 3 K # 4 #							ODE - 2 - 2 4 030 - 3 H # 4 #							A	0			4				2	X	Y
	4	5	9.5	2	ODE - 2 - 2 4 400 - 3 K # 4 #							ODE - 2 - 2 4 050 - 3 H # 4 #							A	0			4				2	X	Y
	5.5	7.5	14	3	ODE - 2 - 3 4 055 - 3 K # 4 #							ODE - 2 - 3 4 075 - 3 H # 4 #							A	0			4				2	X	Y
	7.5	10	18	3	ODE - 2 - 3 4 075 - 3 K # 4 #							ODE - 2 - 3 4 100 - 3 H # 4 #							A	0			4				2	X	Y
	11	15	24	3	ODE - 2 - 3 4 110 - 3 K # 4 #							ODE - 2 - 3 4 150 - 3 H # 4 #							A	0			4				2	X	Y

**kW Models: Factory Settings**  
 Motor Rated Frequency: 50Hz  
 Motor Rated Voltage: 400V

**HP Models: Factory Settings**  
 Motor Rated Frequency: 60Hz  
 Motor Rated Voltage: 460V

Replace # in model code with colour-coded option



## Switched and Non-switched IP66 models available.



### Optidrive E2 IP66

Environmentally protected, the Optidrive E2 IP66 can be mounted directly on your processing equipment.



IP66 / NEMA 4X

### Dust-tight Design

Install in-situ and be sure of protection from dust and contaminants.

### Washdown Ready

With a sealed ABS enclosure and corrosion resistant heatsink, the Optidrive E2 IP66 is ideal for high-pressure washdown applications.

### On-drive Control

IP66 models feature optional, convenient controls for speed control, REV/OFF/FWD and Power ON/OFF, complete with safety lock.

### IP66

#### Recommended for:

- Paper
- Petroleum
- Food Processing
- Aggregate / Cement
- Mining
- Textile
- Horticultural
- Chemical
- Agricultural

## Model Code Guide

ODE-2-12037-3K###

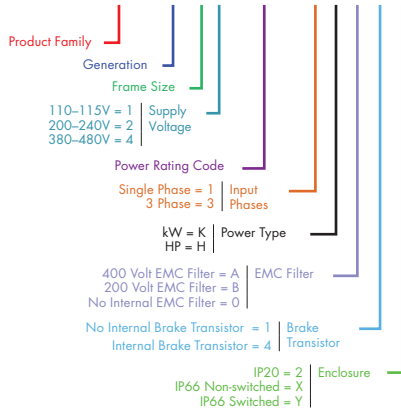

## Drive Specification

Input Ratings	Supply Voltage	110 – 115V ± 10% 200 – 240V ± 10% 380 – 480V ± 10%	I/O Specification	Power Supply	24 Volt DC, 100mA, Short Circuit Protected 10 Volt DC, 5mA for Potentiometer
	Supply Frequency	48 – 62Hz		Programmable Inputs	4 Total as standard 2 Digital 2 Analog / Digital Selectable
	Phase Imbalance	3% Maximum allowed		Digital Inputs	10 – 30 Volt DC, internal or external supply, Response time: < 4ms
	Inrush Current	< rated current		Analog Inputs	Resolution: 12 bits Response time: < 4ms Accuracy: < ± 2% of full scale Parameter adjustable scaling and offset
	Power Cycles	120 per hour maximum, evenly spaced		Programmable Outputs	2 Total 1 Analog / Digital 1 Relay
Output Ratings	Output Power	110V 1 Phase: 0.5–1.5HP (230V 3 Phase Output) 230V 1 Phase: 0.75–4kW / 1–5HP 230V 3 Phase: 0.75–4kW / 1–5HP 400V 3 Phase: 0.75–11kW 460V 3 Phase: 1–15HP	Relay Outputs	Maximum Voltage: 250 VAC, 30 VDC Switching Current Capacity: 6A AC	
	Overload Capacity	150% for 60 seconds 175% for 2 seconds	Analog Outputs	0 to 10 Volt	
	Output Frequency	0 – 500Hz, 0.1Hz resolution	Control Features	PI Control	Internal PI control with feedback display
	Ambient Conditions	Temperature	Storage: –40 to 60°C Operating: –10 to 50°C	Maintenance & Diagnostics	Fault Memory
Programming	Keypad	Built-in Keypad as standard Optional remote mountable keypad	Data Logging	Logging of data prior to trip for diagnostic purposes : Output Current, Drive Temperature, DC Bus Voltage	
	Display	Built-in LED display	Monitoring	Hours Run Meter	
	Programming	OptiTools Studio / Optistick	Standards Compliance	Low Voltage Directive	2006/95/EC  2004/108/EC
Control Specification	Control Method	V/F Voltage Vector Energy Optimised V/F	EMC Directive	230V 1 Phase Filtered Units category C1 according to EN61800-3:2004  400V 3 Phase filtered units category C2 according to EN61800-3:2004	
	PWM Frequency	4 – 32kHz Effective	Machinery Directive	98/37/EC	
	Ramp to Stop	User Adjustable 0.01–600 secs Coast to Stop	Conformance	CE, UL, cUL, C-Tick, GOST	
	Braking	Motor Flux Braking Built-in Braking Transistor (Frames 2 & 3)	Ingress Protection	IP20 IP66 (Excluding 11kW / 15HP)	
	Skip Frequency	Single point, user adjustable			
	Setpoint Control	Analog Signal	0 to 10 Volts 0 to 20mA 20 to 0mA 4 to 20mA 20 to 4mA		
		Digital	Motorised Potentiometer (Keypad) Modbus RTU		
Optional Gateway		PROFIBUS DP, DeviceNet, EtherNet/IP			

NOT TO SCALE



Size	IP20			IP66		
	1	3	3	1	3	3
mm Height	173	221	261	232	257	310
mm Width	83	110	131	161	188	210.5
mm Depth	123	150	175	179	187	245
kg Weight	1.1	2.6	4	2.8	4.6	7.4
Fixings	4 x M4	4 x M4	4 x M4	4 x M4	4 x M4	4 x M4

# OPTIDRIVE™ $E^2$ Single Phase

AC Variable Speed Drive

0.37 – 1.1kW / 0.5 – 1.5HP  
**110 – 240V**

## Single Phase Motor Control

The Optidrive E2 Single Phase is the world's first fully digital, fully packaged variable speed drive for controlling low power single phase motors



### Key Features

- 110 – 115V and 200 – 240V models available
- Single phase input/single phase output
- Small mechanical envelope
- Rugged industrial operation: Up to 50°C ambient rating
- Simple mechanical & electrical installation
- Fast setup, and simple operation. Factory default settings okay for most applications, only 14 basic parameters
- Unique motor control strategy optimised for Single Phase Motors
- Motor current and rpm indication
- Debugging using troubleshooting & P-00
- 150% overload for 60 secs (175% for 2 secs)
- Keypad control
- Integral RFI filter option
- Integral brake chopper (S2 only)
- Modbus RTU serial communications

### Special Boost Phase

To ensure reliable starting, the Optidrive E2 initially ramps the motor voltage up to rated voltage whilst maintaining a fixed starting frequency, before reducing the frequency and voltage to the desired operating point.

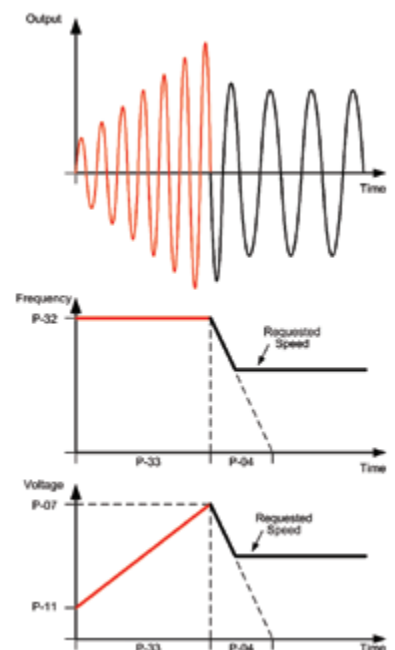

**Designed to be cost effective and easy to use, the Optidrive E2 Single Phase is for use with PSC (Permanent Split Capacitor) or Shaded-Pole Single Phase induction motors.**

Optidrive E2 Single Phase uses a revolutionary motor control strategy to achieve reliable intelligent starting of single phase motors.

Optidrive E2 Single Phase has only 14 standard parameters to adjust in its basic form. The Optidrive's legendary ease of use ensures quick and easy drive commissioning. For the more advanced user the extended parameter set gives access to powerful additional functionality.

### Typical Applications

Optidrive E2 single phase output can be used to provide energy efficient, accurate speed control of single phase motors in a variety of applications, especially fans and pumps which typically do not require high starting torque. The control method used provides significant energy savings compared to alternative methods.



# OPTIDRIVE™ E2

## Single Phase

Input Voltage	kW Model				kW Model Code										HP Model				HP Model Code									
	kW	HP	Amps	Size	Product Range	Generation	Frame Size	Supply Voltage	Power Rating	Input Phases	Power Type	Factory Build Options	Single Phase Output	Product Range	Generation	Frame Size	Supply Voltage	Power Rating	Input Phases	Power Type	Factory Build Options	Single Phase Output						
110–115V ± 10% 1 Phase Input	–	0.5	7	1	N/A										ODE - 2 - 1 1 005 - 1 H				0 1 # -01									
	–	0.75	10.5	2	N/A										ODE - 2 - 2 1 007 - 1 H				0 4 # -01									
200–240V ± 10% 1 Phase Input	0.37	0.5	4.3	1	ODE - 2 - 1 2 037 - 1 K										# 1 # -01													
	0.75	1	7	1	ODE - 2 - 1 2 075 - 1 K										# 1 # -01													
	1.1	1.5	10.5	2	ODE - 2 - 2 2 110 - 1 K										# 4 # -01													

**kW Models: Factory Settings**  
Motor Rated Frequency: 50Hz

**HP Models: Factory Settings**  
Motor Rated Frequency: 60Hz

**Factory Build Options**

- EMC Filter: Low Voltage Filter, No EMC Filter
- Brake Transistor: No Internal Brake Transistor, Internal Brake Transistor
- Enclosure: IP20, IP66 Non-switched, IP66 Switched

EMC Filter	0	1	4	2	X	Y	
Brake Transistor	0	1	4	2	X	Y	
Enclosure	B	0	1	4	2	X	Y
	B	0	1	4	2	X	Y
	B	0	1	4	2	X	Y

Replace # in model code with colour-coded option

## Drive Specification

Input Ratings	Supply Voltage	110 – 115V ± 10% 200 – 240V ± 10%	
	Supply Frequency	48 – 62Hz	
	Phase Imbalance	3% Maximum allowed	
	Inrush Current	< rated current	
	Power Cycles	120 per hour maximum, evenly spaced	
Output Ratings	Output Power	110V 1 Phase Input: 0.5–0.75HP 230V 1 Phase Input: 0.75–1.1kW (1–1.5HP)	
	Overload Capacity	150% for 60 seconds 175% for 2 seconds	
	Output Frequency	0 – 120Hz, 0.1Hz resolution	
	Control Method	Single Phase V/F with Starting Boost	
Ambient Conditions	Temperature	Storage: –40 to 60°C Operating: –10 to 50°C	
	Altitude	Up to 1000m ASL without derating Up to 2000m maximum UL Approved Up to 4000m maximum (non UL) Above 1000m: Derate by 1% per 100m	
	Humidity	95% Max, non-condensing	
Programming	Keypad	Built-in Keypad as standard Optional remote mountable keypad	
	Display	Built-in LED display	
	Programming	OptiTools Studio / Optistick	
Control Specification	PWM Frequency	4 – 32kHz Effective	
	Stopping Mode	Ramp to Stop: User Adjustable 0.1 – 600 seconds Coast to Stop	
	Braking	Motor Flux Braking Built-in Braking Transistor (Size 2 only)	
	Skip Frequency	Single point, user adjustable	
	Setpoint Control	Analog Signal	0 to 10 Volts 0 to 20mA 20 to 0mA 4 to 20mA 20 to 4mA
		Digital	Motorised Potentiometer (Keypad) Modbus RTU
		Optional Gateway	PROFIBUS DP, DeviceNet, EtherNet/IP

I/O Specification	Power Supply	24 Volt DC, 100mA, Short Circuit Protected 10 Volt DC, 5mA for Potentiometer	
	Programmable Inputs	4 Total as standard 2 Digital 2 Analog / Digital Selectable	
	Digital Inputs	10 – 30 Volt DC, internal or external supply, Response time: < 4ms	
	Analog Inputs	Resolution: 12 bits Response time: < 4ms Accuracy: < ± 2% of full scale Parameter adjustable scaling and offset	
	Programmable Outputs	2 Total 1 Analog / Digital 1 Relay	
	Relay Outputs	Maximum Voltage: 250 VAC, 30 VDC Switching Current Capacity: 6A AC, 5A DC	
	Analog Outputs	0 to 10 Volt	
	Control Features	PI Control Internal PI control with feedback display	
	Maintenance & Diagnostics	Fault Memory	Last 4 Trips stored with time stamp
		Data Logging	Logging of data prior to trip for diagnostic purposes: Output Current, Drive Temperature, DC Bus Voltage
Monitoring		Hours Run Meter	
Design Standards	Low Voltage Directive	2006/42/EC	
	EMC Directive	2004/108/EC	
	Machinery Directive	230 Volt 1 Phase unit category C1 according to EN61800-3	
	Conformance	98/37/EC	
	Ingress Protection	CE, UL, eUL, C-Tick, GOST IP20, IP66	

## Model Code Guide

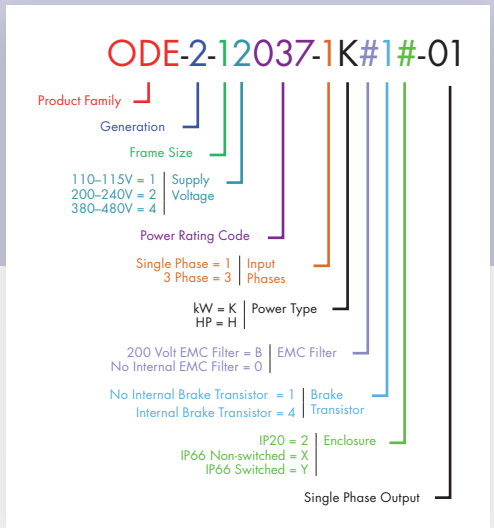

NOT TO SCALE



Size	IP20		IP66	
	1	2	1	2
mm Height	173	221	232	257
mm Width	83	110	161	188
mm Depth	123	150	179	187
kg Weight	1.1	2.6	2.8	4.6
Fixings	4 x M4	4 x M4	4 x M4	4 x M4

# Energy Efficient Fan & Pump Control

- Low Input Harmonic Current Distortion, compliant with EN61000-3-12
- > 98% drive efficiency
- Low audible noise motor operation



**Multi Language  
OLED Display**

**BACnet**

built-in as standard

**Low Harmonics**  
EN61000-3-12  
compliant

Internal  
EMC Filter

## Key Features

- **Low Harmonic Technology**
  - Reduces Supply Total Harmonic Current Distortion (iTHD)
  - Reduces total Supply Current
  - Reduces cable and busbar rating requirements
  - Reduces fuse sizes
  - Reduces required supply transformer load or rating
- **Built In EMC Filters**
  - Compliance with global EMC Standards
- **Advanced Motor Control**
  - Operation with:
    - Standard Induction Motors
    - Permanent Magnet AC Motors
    - Brushless DC Motors
    - Synchronous Reluctance Motors
  - Constant or Variable Torque selectable
  - Maximum motor efficiency
- **Quiet Operation**
  - Temperature controlled cooling fans operate only when required
  - PWM switching technique reduces motor audible noise



### Energy Savings Calculator

Estimate your potential energy savings, CO<sub>2</sub> emissions and financial savings  
[www.invertekdrives.com/calculator](http://www.invertekdrives.com/calculator)



IP55 / NEMA 12



IP66 / NEMA 4X

## Save Energy

**Accurate speed control** of fans and pumps provides the most energy efficient control method

**Energy optimisation function** minimises energy usage in real time under partial load conditions

**Sleep & wake functions** ensure operation only when required

## Save Money

**Advanced on-board features** remove the need for peripheral equipment

**Intelligent maintenance interval** timing allows programmable maintenance reminders, avoiding costly downtime

**Automatic load monitoring** provides an early warning of potential faults, such as belt failures or blocked filters

## Save Time

**Built in keypad and OLED text display** provides intuitive operation

**Simple parameter structure** with carefully selected default values reduce commissioning time

**Practical design** allows easy access to power and control terminals without specialist tools

### Fire Override Mode

Fire override mode ignores signals and alarms, keeping the drive operating for as long as possible.

This feature is crucial for ensuring smoke extraction from buildings in the event of a fire.

Selectable Normally Open or Normally Closed logic means that the Optidrive HVAC Eco can be easily configured to the signal produced by your fire management system.

With an independently set speed for fire mode operation, selectable as either forward or reverse direction, the Optidrive HVAC Eco has the flexibility to match the needs of your fire control system.

### PID Control

The Optidrive HVAC Eco has a PID controller built in that is fully integrated with both HVAC and energy efficient features and is packaged in a user friendly way to ensure ease of use and fast commissioning.

### Stairwell Pressurisation

In the event of a fire, stairwells are often essential escape routes.

Optidrive HVAC Eco can be used to control air flow and pressure to help keep stairwells clear of smoke to allow safe evacuation and give firefighters safe access to buildings.

### Improved Fan Efficiency

#### Energy Optimisation and Monitoring

The advanced optimisation function intelligently matches energy usage to the driven load to ensure your fan operates at maximum efficiency. The in-built energy consumption meters allow energy consumption to be clearly displayed and savings to be calculated.

#### Intelligent Standby

To reduce energy used by slow-running fans, Optidrive HVAC Eco has an intelligent standby/sleep function to shut off output from the drive until demand for air flow increases.

#### Broken Belt Detection

Optidrive HVAC Eco intelligently monitors current/speed to provide immediate warning of broken belts between motors and ventilation fans.

#### Resonance Avoidance

Optidrive HVAC Eco can be easily configured to avoid frequencies that cause resonance in ventilation systems, preventing unnecessary noise and mechanical damage to motors and fans.

# Energy Efficient Pump Control

## OPTIFLOW™

Co-ordinated pump station control, built into each drive as standard, allows independent control of multiple pump applications.

- All pumps operate as variable speed for maximum energy saving.
- Equal run time sharing across every pump.
- Automatic system reconfiguration in the event of a pump fault (including the master pump).
- Continued system operation when drives are individually powered off (including the master drive).
- Communication and +24V control voltage shared between drives via a standard RJ45 patch lead.
- Independent maintenance indicators for each pump.
- Any pump can be switched to Hand operation at the touch of a button, and will automatically rejoin the network when switched back to Auto.
- For waste water applications each pump can be set for blockage/ragging detection and activate an automatic de-ragging/pump cleaning cycle.
- Optional mains isolator with lock-off for safe pump maintenance.
- Optiflow function configured through simple parameter set-up and intelligent drive self configuration.

### Setpoint Control

## OPTIFLOW™

A standard feature on every Optidrive HVAC / HVAC Eco

### Independent pump system control

### OptiFlow Communications

### ← Feedback signal



### See OPTIFLOW™ in action

Scan to watch the video or visit <http://youtu.be/9QQ89bQYdfs>







## Pump Efficiency

### In-built Sleep Mode with Auto-boost

Sleep mode saves energy by detecting when a pump is running inefficiently and producing little useful work. Optidrive HVAC Eco can be programmed to enter into a sleep/disabled mode until the demand increases. To help prevent sleep mode oscillation, Optidrive HVAC Eco can automatically initiate a boost cycle to increase pressure on starting or stopping.

## Drive Controlled Bypass

Intelligent features within the Optidrive HVAC Eco allow a bypass circuit to be implemented. Activation of Bypass mode can be determined intelligently by the Optidrive HVAC Eco drive based on a command from the building management system. The drive can be set to automatically select bypass mode when entering into a trip condition ensuring minimal disruption to service.

## Avoid Pump Downtime

### Blockage Detect/Clear

Optidrive HVAC Eco can detect potential pump blockages in real time and trigger a programmed cleaning cycle to automatically clear them, preventing downtime.

### Pump Clean/Stir Cycle

Triggered by a settable period of inactivity, a configurable cleaning cycle can be run to clear sediment, ensuring the pump is ready to run when needed.

### Dry Run Protection

Optidrive HVAC Eco can evaluate a pump's speed/power and shut it off or warn when the pump starts to run dry, protecting it from heat/friction damage.

## Cascade Control Pump Staging

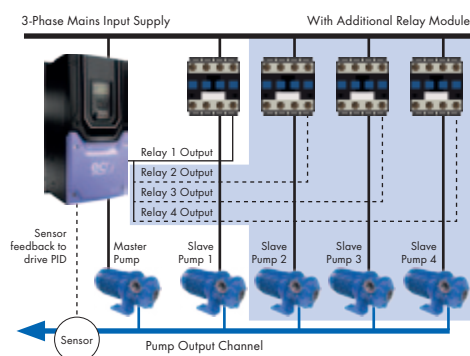

### Variable speed duty pump with up to 4 assist pumps

Optidrive HVAC Eco can provide automatic operating time monitoring and balancing for assist pumps to share duty cycle. Run time clocks for all fixed speed assist pumps are maintained and visible within the Optidrive HVAC Eco for integration into the pump system maintenance schedules.

### Motor Preheat Function

Optidrive HVAC Eco features a motor preheat function to help ensure moisture is not permitted to collect on the motor in periods of inactivity and prior to motor start up. In addition, the motor preheat function can be used to keep condensation from developing on the motor as the motor cools down immediately following a stop. The feature is fully configurable, meaning the pump can be always available the instant it is required.

kW	HP	Amps	Size	Model Code	Product Range	Generation	Frame Size	Supply Voltage	Capacity	Input Phases	Factory Build Options
380-480V ± 10% 3 Phase Input	0.75	1	2.2	2	ODV - 3 - 2 4 0022 - 3	F	1	T	#		
	1.5	2	4.1	2	ODV - 3 - 2 4 0041 - 3	F	1	T	#		
	2.2	3	5.8	2	ODV - 3 - 2 4 0058 - 3	F	1	T	#		
	3	4	7.7	2	ODV - 3 - 2 4 0077 - 3	F	1	T	#		
	4	5	9.5	2	ODV - 3 - 2 4 0095 - 3	F	1	T	#		
	5.5	7.5	14	3	ODV - 3 - 3 4 0140 - 3	F	1	T	#		
	7.5	10	18	3	ODV - 3 - 3 4 0180 - 3	F	1	T	#		
	11	15	24	3	ODV - 3 - 3 4 0240 - 3	F	1	T	#		
	11	15	24	4	ODV - 3 - 4 4 0240 - 3	F	1	T	#		
	15	20	30	4	ODV - 3 - 4 4 0300 - 3	F	1	T	#		
	18.5	25	39	4	ODV - 3 - 4 4 0390 - 3	F	1	T	#		
	22	30	46	4	ODV - 3 - 4 4 0460 - 3	F	1	T	#		
	30	40	61	5	ODV - 3 - 5 4 0610 - 3	F	1	T	#		
	37	50	72	5	ODV - 3 - 5 4 0720 - 3	F	1	T	#		
	45	60	90	5	ODV - 3 - 5 4 0900 - 3	F	1	T	#		

**Factory Build Options**

Option	F	1	T	#
EMC Filter			X	D
Internal EMC Filter			X	D
Brake Transistor			X	D
No Brake Transistor				
Enclosure			X	D
IP35			X	D
IP66 Non-wick-bed			X	D
IP66 with Isolator			X	D
Display				
OLED Display				
PCB Coating				
Standard Coating				
Full Conformal Coating				

Replace # in model code with colour-coded option

**Reduced Harmonic Current Distortion**

Optidrive HVAC Eco is a dedicated 'low harmonics' drive that uses the latest technology to minimise disruption (harmonics) of the incoming mains power supply which can be created by non-linear loads, such as AC drives. The third generation HVAC drive can reduce harmonic current distortion to below 30% iTHD (Total Harmonic Distortion), whilst also increasing efficiency by reducing the input current levels – leading to reduced life time costs.

**Optidrive HVAC Eco delivers...**

- Lower mains supply current - reduced cable size, reduced fuse size, reduced transformer size
- Improved power factor - no additional charges from the electricity supply company due to low power factor
- Improved efficiency - Reduced Life Time Costs. E.g. 37kW, operating 10 hours per day, 5 days per week, 50 weeks per year - Power Consumption is 92500kWh - 1.1% reduction is > 100kWh saving

Typical Total Harmonic Current Distortion (iTHD) and efficiency comparison for Optidrive HVAC Eco vs other AC variable speed drives

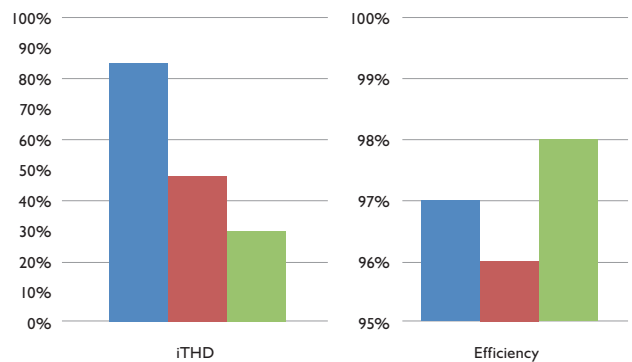

■ Standard AC Variable Speed Drive  
■ AC Variable Speed Drive + 4% Line Choke  
■ Optidrive HVAC Eco

**EN61000-3-12 compliant**

## Drive Specification

Input Ratings	Supply Voltage	380 – 480V ± 10%	
	Supply Frequency	48 – 62Hz	
	Displacement Power Factor	> 0.98	
	Phase Imbalance	3% Maximum allowed	
	Inrush Current	< rated current	
	Power Cycles	120 per hour maximum, evenly spaced	
	Total Harmonic Current Distortion	< 30% iTHD	
Output Ratings	Output Power	0.75 – 45kW / 1 – 60HP	
	Overload Capacity	110% for 60 seconds	
	Output Frequency	0 – 500Hz, 0.1Hz resolution	
	Typical Efficiency	98%	
Ambient Conditions	Temperature	Storage: –40 to 60°C Operating: –10 to 50°C	
	Altitude	Up to 1000m ASL without derating Up to 2000m maximum UL approved Up to 4000m maximum (non UL) Derate 1% per 100m above 1000m	
	Humidity	95% without condensing, dripping water or ice forming, according to IEC 60068-2-78	
	Vibration	Conforms to IEC 60068-2-6 Sinusoidal Vibration Frequency Range: 10 – 150Hz 10 – 57Hz @ 0.075mm Pk 57 – 150Hz @ 1g Pk	
Programming	Keypad	Built-in keypad as standard Optional remote keypad	
	Display	Multi language OLED display	
	PC	OptiTools Studio	
Control Specification	Control Method	IM Motors PM Motors BLDC Motors SynRel Motors Sensorless Vector CT / VT Operation	
	PWM Frequency	10–32kHz Effective	
	Stopping Mode	Ramp to Stop: User Adjustable 1–600 seconds Coast to Stop	
	Braking	Motor Flux Braking	
	Resonance Avoidance	Skip frequency	
	Setpoint Control	Analog Signal	0 to 10 Volts 10 to 0 Volts 0 to 20mA 4 to 20mA 20 to 4mA 20 to 0mA
		Digital	Motorised Potentiometer Modbus RTU BACnet MS/TP Optional BACnet IP, PROFIBUS DP, DeviceNet, EtherNet/IP, EtherCAT, Modbus TCP, PROFINET IO
I/O Specification	Power Supply	24 Volt DC, 100mA, Over Current Protected 10 Volt DC, 5mA	
	Programmable Inputs	5 Onboard (Optional Additional 3) 2 Analog / Digital 3 Digital	
	Digital Inputs	10 – 30 Volt DC, Internal or External Supply PNP Response time: < 4ms	
	Analog Inputs	Resolution: 12 bits Response time: < 4ms Accuracy: Better than 1% Full Scale Parameter adjustable scaling and offset	
	Programmable Outputs	4 Total (Optional additional 3) 2 Analog / Digital 2 Relays (Optional additional 3)	
	Relay Outputs	Maximum Voltage: 250 VAC, 30 VDC Switching Current: 6A AC, 5A DC	
Analog Outputs	0 – 10 Volts 0 – 20mA 4 – 20mA		

Control Features	Fire Mode	Selectable Speed Setpoint (Fixed / PID / Analog / Fieldbus) Selectable Direction
	PID Control	Internal PID Controller Multi Setpoint Select Standby / Sleep Mode
	Load Monitoring	Over Torque Protection (Fan / Pump Blocked) Under Torque Protection (Broken Belt / Shaft / Impeller)
	Duty / Assist / Standby	Automated Changeover for Duty / Standby Automatic Assist Control
Fieldbus	BACnet MS/TP	Built in BACnet MS / TP interface (BacNet Application Specific Controller) 9.6 – 76.8 kbps selectable Date Format: 8N1, 8N2, 8E1, 8O1
	Modbus RTU	Built In Modbus RTU 9.6 – 115.2 kbps selectable User Selectable Format
	BACnet IP	Optional Plug In BACnet IP Interface (BacNet Application Specific Controller) Dual LAN ports with switch support Device Level Ring
	Modbus TCP	Optional Plug In Modbus TCP Interface Dual LAN ports with switch support Device Level Ring Read / Write Parameter access
Other	Optional Fieldbus Interfaces for: PROFINET IO PROFIBUS DP (DPV1) DeviceNet EtherNet/IP EtherCAT	
Maintenance & Diagnostics	Cooling	Long life dual ball bearing fans Fan operation time monitoring
	Fault Memory	Last 4 Trips
	Critical Fault Counters	Over Current Over Voltage Over Temperature Mains Loss Communications Loss
	Data Logging	Logging of critical data for diagnostic prior to last trip: Output Current DC Link Voltage Heatsink Temperature
High Speed Scope Data Logger	High Speed Scope Data Logger	1ms sample time Download & Trace via OptiTools Studio PC Software
	Real Time Usage	Run Time Counter Energy Consumption Meter External Real Time Data Logging via RS485 or Bluetooth to OptiTools Studio PC software
	Maintenance Indicator	User programmable Maintenance Warning Timer
Design Standards	Low Voltage Directive	2006 / 95 / EC
	EMC Directive	2004 / 108 / EC Category C1 / C2 according to EN61800-3: 2004 EN61000-3-12
	Machinery Directive	98 / 37 / EC
	Conformance	UL, cUL, C-Tick
Ingress Protection	IP55, IP66	

## Model Code Guide

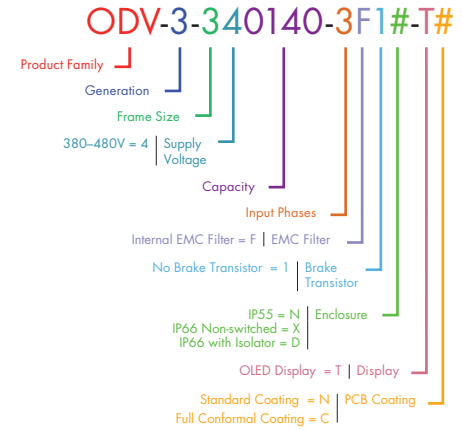

## Connection Diagram

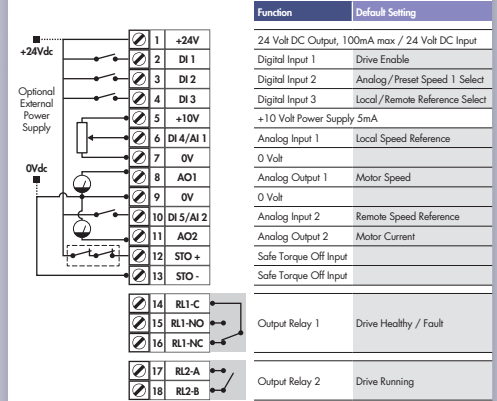

NOT TO SCALE



Size	IP66		IP55	
	2	3	4	5
mm Height	257	310	440	540
mm Width	188	211	171	235
mm Depth	260	273	252	270
kg Weight	4.8	7.3	11.5	22.5

# OPTIDRIVE™ HVAC

AC Variable Speed Drive

0.75 – 250kW / 1 – 350HP  
200 – 480V Single & 3 Phase Input

## Energy Efficient Fan & Pump Control

from a reliable, compact range of drives dedicated to pumping and HVAC systems

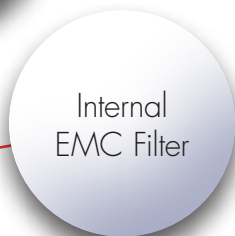

### Key Features

- Dedicated HVAC drive for centrifugal fan and pump applications
- Built-in EMC Filter as standard
- IP55 Enclosed
- Multi Language Plain Text OLED display
- Energy optimisation maximises operating efficiency
- BACnet and Modbus RTU provided as standard
- Built-in Hours Run and kWh meters
- Bi-directional Fire Mode overrides the drive control providing ventilation in emergencies
- Built-in PID controller allows setpoint pressure or temperature to be accurately maintained
- Advanced software application functions reduce commissioning time and provide optimum performance
- Up to 32kHz output switching frequency for quiet motor operation
- Built-in Sleep and Wake functions ensure operation only when required

## OPTIFLOW™

Multiple pump control

See page 16



IP55 / NEMA 12

Up to 160kW



IP66 / NEMA 4X

Up to 7.5kW



### Energy Savings Calculator

Estimate your potential energy savings, CO<sub>2</sub> emissions and financial savings

[www.invertekdrives.com/calculator](http://www.invertekdrives.com/calculator)







**Hand/Auto Selection**



**Integrated Cable Management**

**Service Indicator**



**Multi Language OLED Display**



**High Quality Long-life Fans**



## Hand / Auto



Allows manual control to easily be selected in the event of an automatic control system failure or for simplified commissioning/system checks, or when a fast temporary override of the control system is required. Built-in 'Auto Control Selection' allows return to automatic system control just as easily.

## Controlling Your HVAC System

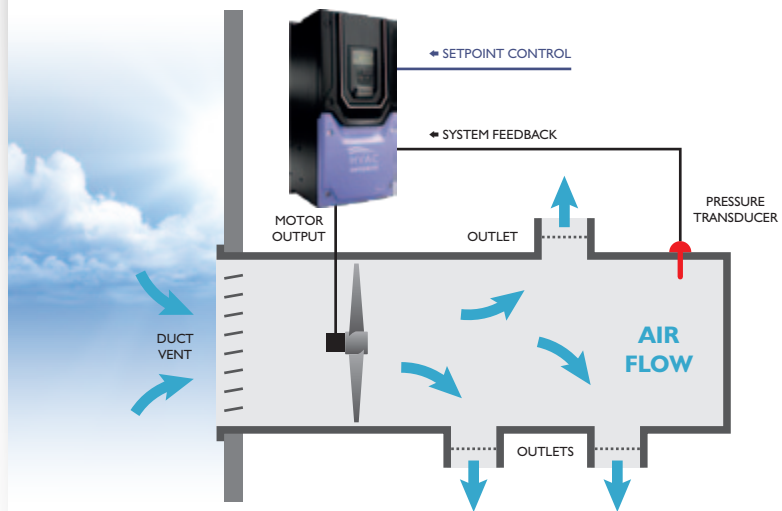

## Drive Controlled Bypass

Optidrive HVAC can operate as a bypass controller when installed as part of a bypass circuit. Activation of Bypass mode can be determined intelligently by the Optidrive HVAC drive based on a command from the building management system. Additionally the drive can be set to automatically select bypass mode when entering into a trip condition ensuring minimal disruption to service.

Optidrive HVAC has a PID controller built in that is fully integrated with both HVAC and energy efficient features and is packaged in a user friendly way to ensure ease of use and fast commissioning. Now in the majority of applications it has become possible to eliminate the need for external controllers.



## Drive Specification

Input Ratings	Supply Voltage	200 – 240V ± 10% 380 – 480V ± 10% 480 – 525V ± 10% 500 – 600V ± 10%	
	Supply Frequency	48 – 62Hz	
	Displacement Power Factor	> 0.98	
	Phase Imbalance	3% Maximum allowed	
	Inrush Current	< rated current	
	Power Cycles	120 per hour maximum, evenly spaced	
	Output Ratings	Output Power	230V 1 Phase: 0.75 – 37kW 230V 3 Phase: 0.75 – 75kW 400V 3 Phase: 0.75 – 25kW 525V 3 Phase: 0.75 – 20kW 575V 3 Phase: 0.75 – 11kW / 1 – 150HP
Overload Capacity		110% for 60 seconds	
Output Frequency		0 – 120Hz, 0.1Hz resolution	
Typical Efficiency		98%	
Ambient Conditions		Temperature	Storage: –40 to 60°C Operating: –10 to 50°C
Altitude	Up to 1000m ASL without derating Up to 2000m maximum UL approved Up to 4000m maximum (non UL) Above 1000m: Derate by 1% per 100m		
	Humidity	95% Max, non-condensing	
Programming	Keypad	Built-in keypad as standard Optional remote mountable keypad	
	Display	Built-in multi language OLED display (except IP20) LED display (IP20 only)	
	PC	OptiTools Studio	
	Control Method	Dedicated Fan & Pump Control Constant or Variable torque	
Control Specification	PWM Frequency	4–32kHz Effective	
	Stopping Mode	Ramp to Stop: User Adjustable 1–600 seconds Coast to Stop	
	Braking	Motor Flux Braking	
	Skip Frequency	Single point, user adjustable	
	Setpoint Control	Analog Signal	0 to 10 Volts 10 to 0 Volts –10 to 10 Volts 0 to 20mA 20 to 0mA 4 to 20mA 20 to 4mA
		Digital	Motorised Potentiometer (Keypad) Modbus RTU BACnet MS/TP
		Optional	BACnet/IP, PROFIBUS DP, DeviceNet, EtherNet/IP, PROFINET, Modbus TCP, EtherCAT

I/O Specification	Power Supply	24 Volt DC, 100mA, Short Circuit Protected 10 Volt DC, 5mA for Potentiometer	
	Programmable Inputs	5 Total as standard (Optional additional 3) 3 Digital (Optional additional 3) 2 Analog / Digital Selectable	
	Digital Inputs	10 – 30 Volt DC, internal or external supply, PNP Response time: < 4ms	
	Analog Inputs	Resolution: 12 bits Response time: < 4ms Accuracy: < 1% full scale Parameter adjustable scaling and offset	
	Programmable Outputs	4 Total (Optional additional 3) 2 Analog / Digital 2 Relays (Optional additional 3)	
	Relay Outputs	Maximum Voltage: 250 VAC, 30 VDC Switching Current Capacity: 6A AC, 5A DC	
	Analog Outputs	0 to 10 Volt 0 to 20mA 4 to 20mA	
	Control Features	Fire Mode	Selectable direction Selectable speed reference
		Broken Belt Detection	Under load monitoring with autotune configuration
		PID Control	Internal PID control with feedback display
Pump Control Features	Pump Blockage Detection	Pump load monitoring with autotune function, user configurable	
	Pump Cleaning	Adjustable Pump Cleaning Cycle operation	
	Multi-pump Control	Control of fixed speed assist pumps via optional cascade control module Control of Duty, Assist and Standby variable speed pumps via internal Master – Slave network	
Pump Stir	Automatic pump stir function		
Maintenance & Diagnostics	Fault Memory	Last 4 Trips stored with time stamp	
	Data Logging	Logging of data prior to trip for diagnostic purposes: Output Current, Drive Temperature, DC Bus Voltage	
	Maintenance Indicator	Maintenance Indicator with user adjustable maintenance interval Onboard service life monitoring	
	Monitoring	Hours Run Meter Resettable & Non Resettable kWh meters	
	Design Standards	EN 61800-3:2004 Adjustable speed electrical power drive systems. EMC requirements. Low Voltage Directive 2006/95/EC Machinery Directive 2006/42/EC Conformance CE, UL, eUL, C-Tick, GOST Ingress Protection IP20 (Size 2, 3, 8) IP55 (Size 4, 5, 6, 7) IP66 (Size 2, 3; up to 7.5kW)	

## Model Code Guide

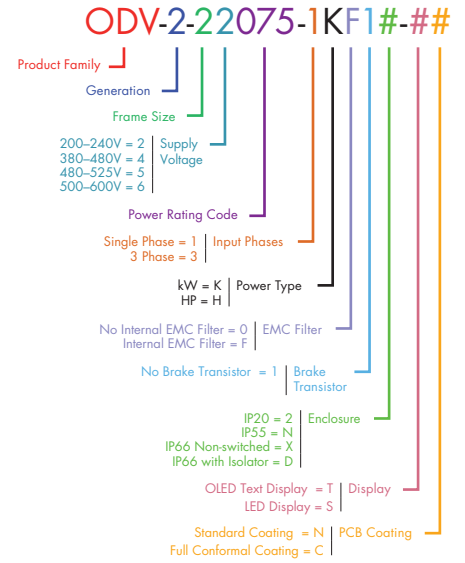

## Connection Diagram

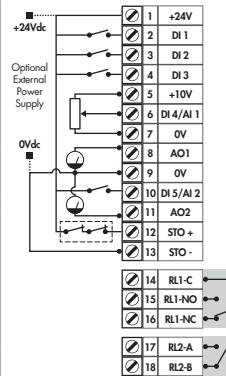

Function	Default Setting
24 Volt DC Output, 100mA max / 24 Volt DC Input	
Digital Input 1	Drive Enable
Digital Input 2	Analog / Preset Speed 1 Select
Digital Input 3	Local / Remote Reference Select
+10 Volt Power Supply 5mA	
Analog Input 1	Local Speed Reference
0 Volt	
Analog Output 1	Motor Speed
0 Volt	
Analog Input 2	Remote Speed Reference
Analog Output 2	Motor Current
Safe Torque Off Input	
Safe Torque Off Input	
Output Relay 1	Drive Healthy / Fault
Output Relay 2	Drive Running

NOT TO SCALE



Size	IP20		IP66		IP55			IP20
	2	3	2	3	4	5	6	8
mm Height	221	261	257	310	440	540	865	1005
mm Width	110	131	188	211	171	235	330	480
mm Depth	185	205	239	266	252	270	330	480
kg Weight	1.8	3.5	4.8	7.3	11.5	22.5	50	200

## The Integrated Drive Solution

Compact yet powerful, Optidrive PCE is the ideal solution for convenient motor control



### Key Features

- High performance drive suitable for direct motor mounting
- Sensorless vector control—up to 200% torque from zero speed
- IP55 enclosure protects against dust and fluid ingress
- Available with local Potentiometer and forward / reverse selection
- Suitable for motor power ratings up to 1.5kW/2HP
- Supplied with universal adaptor plates

### Switched & Non-switched Units Available

Local potentiometer for speed control

**Programmable switch:**

Drive REV/OFF/FWD  
 or:  
 Hand/OFF/Auto



Switched



Non-switched

### Universal Adaptor Plates

Supplied with 2 adaptor plates for direct fitting on most motors.



Deep adaptor plate



Shallow adaptor plate



# OPTIDRIVE™ PCE

kW	HP	Amps	Size	kW Model Code						HP Model Code									
				Product Range	Generation	Frame Size	Supply Voltage	Power Rating	Input Phases	Power Type	Factory Build Options	Product Range	Generation	Frame Size	Supply Voltage	Power Rating	Input Phases	Power Type	Factory Build Options
200–240V ± 10% 1 Phase Input	0.75	1	4.3	1	OPC	- 1 - 1 2	075 - 1	K	# 1 #	OPC	- 1 - 1 2	010 - 1	H	# 1 #	OPC	- 1 - 1 2	020 - 1	H	# 1 #
	1.5	2	7	1	OPC	- 1 - 1 2	150 - 1	K	# 1 #	OPC	- 1 - 1 2	020 - 1	H	# 1 #	OPC	- 1 - 1 2	020 - 1	H	# 1 #
380–480V ± 10% 3 Phase Input	0.75	1	2.2	1	OPC	- 1 - 1 4	075 - 3	K	# 1 #	OPC	- 1 - 1 4	010 - 3	H	# 1 #	OPC	- 1 - 1 4	020 - 3	H	# 1 #
	1.5	2	4.1	1	OPC	- 1 - 1 4	150 - 3	K	# 1 #	OPC	- 1 - 1 4	020 - 3	H	# 1 #	OPC	- 1 - 1 4	020 - 3	H	# 1 #

- EMC Filter
- Low Voltage Filter
- High Voltage Filter
- No EMC Filter
- Brake Transistor
- No Internal Brake Transistor
- Enclosure
- IP20

## Factory Build Options

B	0	1	2
B	0	1	2
A	0	1	2
A	0	1	2

Replace # in model code with colour-coded option

### kW Models: Factory Settings

Motor Rated Frequency: 50Hz  
Motor Rated Voltage: 400V

### HP Models: Factory Settings

Motor Rated Frequency: 60Hz  
Motor Rated Voltage: 460V

## Drive Specification

Input Ratings	Supply Voltage	200 – 240V ± 10% 380 – 480V ± 10%	I/O Specification	Power Supply	24 Volt DC, 100mA, Short Circuit Protected
	Supply Frequency	48 – 62Hz		Programmable Inputs	4 Total as standard 2 Digital 2 Analog / Digital Selectable
	Phase Imbalance	3% Maximum allowed		Digital Inputs	10 – 30 Volt DC, internal or external supply, Response time: < 4ms
	Inrush Current	< rated current		Analog Inputs	Resolution: 12 bits Response time: < 4ms Accuracy: < ± 2% of full scale Parameter adjustable scaling and offset
	Power Cycles	120 per hour maximum, evenly spaced		Programmable Outputs	1 Relay
Output Ratings	Output Power	230 Volt 1 Phase: 0.75 – 1.5kW / 1 – 2HP 400 Volt 3 Phase: 0.75 – 1.5kW / 1 – 2HP	Relay Output	Maximum Voltage: 250 VAC, 30 VDC Switching Current Capacity: 6A	
	Overload Capacity	150% for 60 seconds 175% for 2 seconds	Control Features	PID Control Internal PID control with feedback display	
	Output Frequency	0 – 500Hz, 0.1Hz resolution	Maintenance & Diagnostics	Fault Memory Last 4 Trips stored with time stamp Monitoring Energy Consumption meter	
Ambient Conditions	Temperature	Storage: –40 to 60°C Operating: –10 to 40°C	Design Standards	EN 61800-3:2004 Adjustable speed electrical power drive systems. EMC requirements.	
	Altitude	Up to 1000m ASL without derating Up to 2000m maximum UL Approved Up to 4000m maximum (non UL) Above 1000m: Derate by 1% per 100m	Ingress Protection	IP55	
	Humidity	95% Max, non-condensing			
Programming	Keypad	Optional remote mountable keypad			
	PC	Optistore V3			
Control Specification	Control Method	V/F Voltage Vector Energy Optimised V/F Sensorless Vector Speed Control Sensorless Vector Torque Control			
	PWM Frequency	4 – 32kHz Effective			
	Stopping Mode	Ramp to Stop: User Adjustable 0.1 – 600 seconds Coast to Stop			
	Braking	Motor Flux Braking			
	Skip Frequency	Single point, user adjustable			
	Setpoint Control	Analog Signal 0 to 10 Volts 0 to 20mA 20 to 0mA 4 to 20mA 20 to 4mA Digital Motorised Potentiometer (Keypad)			

## Model Code Guide

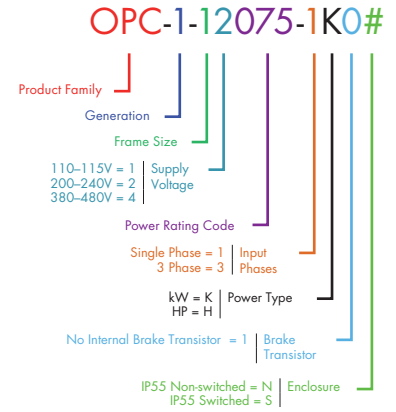

## Keypads & Displays

### OPTIPOINT 2

Remote Keypad & LED Display

**Product Code:** OPT-2-OPORT-IN



### OPTIPAD

Remote Keypad & OLED Display



#### Optipad Language Support

OPT-2-OPPAD-IN	OPT-2-OPDTK-IN
English	English
German	German
Spanish	Turkish
Italian	
French	
Swedish	
Russian	
Polish	
Portuguese	
Finnish	

Optipoint 2 and Optipad units act as the remote keypad and display for the Optidrive on the network which has the same serial address. The physical layout and the operation of the Optipoint keypad and display mimic the Optidrive exactly.

#### Specification

#### OPTIPOINT 2

- Real-time keypad and display operation mimics Optidrive
- Single electrical interface for power and data
- Communicates with any compatible drive across a network
- Easy keypad switching to other network addresses
- IP54 rated when through panel mounted
- Bright LED Display
- Membrane keypad
- Parameter lock function available
- 3m Data Cable included

#### OPTIPAD

In addition to Optipoint 2 features, Optipad benefits from:

- Multi-language OLED Display
- IP55 rated

- Simple plug in RJ45 connection
- 24 Volt DC Power provided directly by the Optidrive
- RS485 2 Wire Signal Interface
- Operating Temperature: -10°C to +50°C
- Storage Temperature: -40°C to +60°C

#### Compatible with:

Optidrive E2  
Optidrive P2  
Optidrive HVAC  
Optidrive HVAC Eco

#### Configuration

Depending on the requirement of the application, Optipoint 2 and Optipad keypads can be used in the following different ways:

##### 1 keypad with 1 drive



##### 1 keypad with multiple Optidrives (up to 63 max)



##### 2 keypads with one drive



















##### 2 keypads with multiple Optidrives (up to 63 max)



Add a communication interface or extend functionality

Opldrive Compatibility

			P2	Eco	HVAC			
Field Bus			<b>OPT-2-PROFB-IN</b> Supports PROFIBUS DPV1 Automatic Baud rate detection from 9.kkbps to 12mbps			<input checked="" type="checkbox"/>	<input checked="" type="checkbox"/>	<input checked="" type="checkbox"/>
			<b>OPT-2-DEVNT-IN</b> Galvanically isolated bus electronics Automatic baud rate detection CIP Parameter Object Support			<input checked="" type="checkbox"/>	<input checked="" type="checkbox"/>	<input checked="" type="checkbox"/>
			<b>OPT-2-ETHNT-IN</b> Two Ethernet /IP ports 10/100Mbit half duplex operation Supports DLR (Device Level Ring) and Linear network topology CIP Parameter object support			<input checked="" type="checkbox"/>	<input checked="" type="checkbox"/>	<input checked="" type="checkbox"/>
			<b>OPT-2-MODIP-IN</b> Two Ethernet /IP ports 10/100Mbit half duplex operation Modbus TCP with IT functionality			<input checked="" type="checkbox"/>	<input checked="" type="checkbox"/>	<input checked="" type="checkbox"/>
			<b>OPT-2-ETCAT-IN</b> Two Ethernet /IP ports 10/100Mbit half duplex operation EtherCAT slave device			<input checked="" type="checkbox"/>	<input checked="" type="checkbox"/>	<input checked="" type="checkbox"/>
			<b>OPT-2-PFNET-IN</b> Two Ethernet /IP ports 10/100Mbit half duplex operation			<input checked="" type="checkbox"/>	<input checked="" type="checkbox"/>	<input checked="" type="checkbox"/>
			<b>OPT-2-BNTIP-IN</b> Two Ethernet /IP ports 10/100Mbit half duplex operation Supports Linear network topology			<input checked="" type="checkbox"/>	<input checked="" type="checkbox"/>	<input checked="" type="checkbox"/>
Encoder Feedback		<b>OPT-2-ENCOD-IN</b> Suitable for standard TTL type encoders Up to 4096ppr 5 Volt Power Supply on board Maximum Input Frequency up to 500kHz			<input checked="" type="checkbox"/>			
		<b>OPT-2-ENC24-IN</b> Suitable for 24 Volt HTL type encoders Up to 4096ppr Up to 500kHz input frequency			<input checked="" type="checkbox"/>			
Extended I/O		<b>OPT-2-EXTIO-IN</b> Provides an additional 3 Digital Inputs 2 Relay (Volt Free) Outputs			<input checked="" type="checkbox"/>	<input checked="" type="checkbox"/>	<input checked="" type="checkbox"/>	
		<b>OPT-2-CASCD-IN</b> Provides an additional 3 Relay (Volt Free) Outputs Typical usage: Cascade control of Booster Pump sets			<input checked="" type="checkbox"/>	<input checked="" type="checkbox"/>	<input checked="" type="checkbox"/>	
External IO		<b>OPT-2-CANIO-IN</b> Standalone external I/O module Additional 5 digital inputs Additional 3 relay outputs Connects via RJ45 socket			<input checked="" type="checkbox"/>			

# OptiTools Studio

## OPTISTICK

Rapid Commissioning Tool

Product Code: OPT-2-STICK-IN

## Powerful PC Software

Drive commissioning and parameter backup



- Powerful PC based commissioning and programming software
- Multi Drive Network Support

### Supports two key functions:

- Drive Programming & Commissioning
  - Parameter Upload, Download & Storage
  - Changed Parameter Highlighting
  - Parameter List Printing
- Provides Access to Optidrive P2 & HVAC PLC programming function
  - Function Blocked Based PLC Logic Programming
  - Advanced Drive Control Functions
  - Multiple Functions can be easily combined to produce powerful solutions
  - Program protection to prevent unauthorised copying
- Real-time scope function and data logging
- Real-time data monitoring

- Allows rapid copying of parameters between multiple drives
- Provides Bluetooth wireless interface to a PC running OptiTools Studio
- Backup and restore of drive parameters

### Compatible with:

Optidrive E2, Optidrive P2, Optidrive HVAC, Optidrive HVAC Eco

### Compatible with:

Windows XP, Windows Vista & Windows 7





## PC Connection Kit

**Product Code:** OD-485AD



485AD PC Connection Kit is an isolated USB to RS485 communications adaptor designed for use with OptiTools Studio

### Key Benefits

- To provide interface between PC and drive
- For use with OptiTools Studio PC software
- Panel mount possibility
- Provides electrical isolation between PC and drive network

### Components in this package

- USB-485 adaptor
- User and Installation guides
- USB cable
- DB9 > RJ11 Cable (For Optidrive Plus / VTC / PCE)
- DB9 > RJ45 Cable (For Optidrive P2 / HVAC / E2)
- Windows driver CD

### Configuration

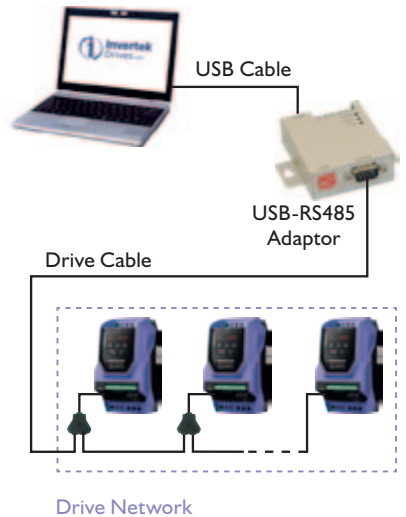

## RS485 Data Cable Splitter

RS485 Data Cable Splitter

**Product Code:** OPT-J45SP (RJ45 1 - 2 way)

RS485 data cable splitter is an RJ45 1 to 2-way connection block



## RJ45 Data Cables

RJ45 to RJ45 RS485 Data Cable, 0.5m length, Blue

**Product Code:** OPT-J4505

RJ45 to RJ45 RS485 Data Cable, 1.0m length, Blue

**Product Code:** OPT-J4510

RJ45 to RJ45 RS485 Data Cable, 3.0m length, Blue

**Product Code:** OPT-J4530



## RJ45 8 Way Network Hub

**Product Code:** OPT-2-RJHUB-IN

# Input Chokes

## Reduce supply harmonic current distortion and increase protection against mains voltage spikes and notches

Input chokes can be used to reduce the supply line harmonic currents and voltage distortion generated by almost all inverter drives on the market today. Invertek Drives have selected a range of chokes matched to the Optidrive range to provide the best reduction in supply current harmonics whilst also providing enhanced protection for the Optidrive against transient voltages ('spikes') or other mains borne interference.

Input chokes are available for the complete range of Optidrive products, and are recommended for use in all installations and in particular:

- where the local mains supply quality may be poor or unknown
- where high current switching loads such as large DC drives or soft starts are operating
- where the mains supply impedance is low
- in remote areas prone to lightning strikes

## Fourier Analysis of Harmonic Distortion

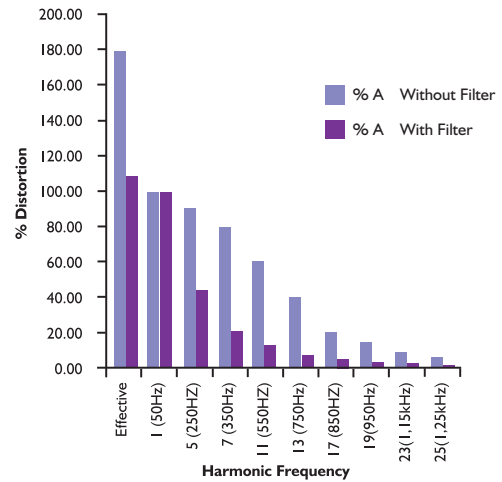

The graph shows the effect of using an input choke on typical 4kW/ 5HP drive. The 50Hz current is used as a reference and is the current which delivers the useful power to the motor. The reduction in the total effective (RMS) current is clear.

Part Number	Optidrive Size	Enclosure IP	Connection (mm <sup>2</sup> )	L (mm)	H (mm)	B (mm)	Rated Volts	Rated Amps	Inductance (mH)	Weight (kg)
<b>OPT-2-L1016-20</b>	1	20	4	78	80	78	230 Max	16	1.8	1.1
<b>OPT-2-L1025-20</b>	2	20	10	85	158	76		25	1.1	1.8
<b>OPT-2-L3006-20</b>	1	20	2.5	95	107	56	500 Max	6	4.8	1.3
<b>OPT-2-L3010-20</b>	2	20	2.5	125	127	71		10	2.9	2.5
<b>OPT-2-L3036-20</b>	3	20	10	190	205	82		36	0.81	7.2
<b>OPT-2-L3050-20</b>	4	20	16	190	220	102		50	0.58	8.7
<b>OPT-2-L3090-20</b>	5	20	35	240	280	107		90	0.32	16
<b>OPT-2-L3200-00</b>	6	00	9	310	260	180	500	200	73.5	35
<b>OPT-2-L3300-00</b>	7	00	9	370	310	180		300	49.0	48
<b>OPT-2-L1016-66</b>	1	66	4	82	70	70	230 Max	16	1.83	1.0
<b>OPT-2-L1025-66</b>	2	66	10	90	75	84		25	1.17	1.3
<b>OPT-2-L3006-66</b>	1	66	2.5	115	88	74	600 Max	6	4.8	1.6
<b>OPT-2-L3010-66</b>	2	66	2.5	175	137	99		10	3.86	3.5
<b>OPT-2-L3018-66</b>	3	66	10	175	137	114		18	2.04	7

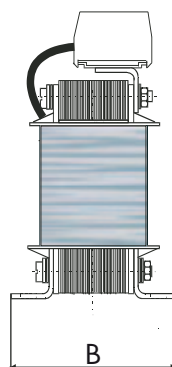
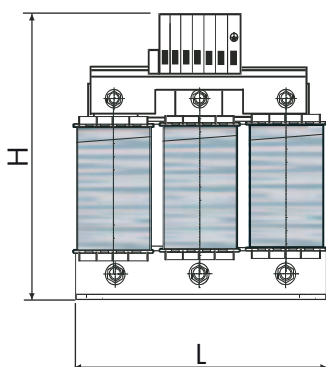

## Output filters improve the quality of the output waveform

In most applications, the unfiltered output from an inverter drive gives satisfactory performance but to improve system functionality, reliability and longevity, output filtering is strongly recommended in some applications, including:

- Long motor cables, up to 200m
- High capacitance motor cables (i.e. typical “pyro” wire, used for fire protection)
- Multiple motors connected in parallel
- Motors without inverter grade insulation (typically older motors)

## Key Features

- Limits output voltage gradient, typically  $<200V/\mu s$
- Limits transient over voltages at the motor terminals, typically  $<1000V$
- Suppression of mains conducted interference in lower frequency ranges
- Compensation of capacitive load currents
- Reduction of RFI emissions from the motor cable
- Reduction of motor losses and audible noise caused by ripple

## Comparison of Characteristics

Without filter

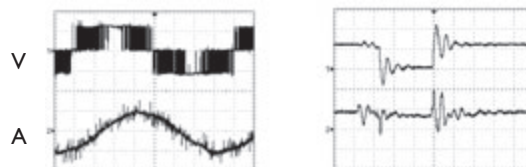

Switching pulse

With filter

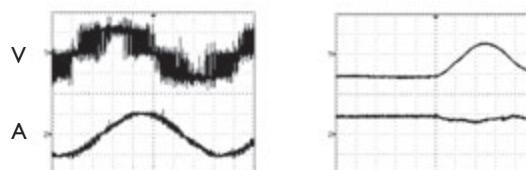

Switching pulse

Note: Switching pulse rises slower and to a lower amplitude with filter.

Part Number	Optidrive Size	Enclosure IP	Connection (mm <sup>2</sup> )	L (mm)	H (mm)	B (mm)	Rated Volts	Rated Amps	Inductance (mH)	Weight (kg)
<b>OPT-2-M3008-20</b>	1	20	2.5	95	107	61	500 Max	8	2.0	1.5
<b>OPT-2-M3012-20</b>	2	20	4	125	158	76		12	1.7	2.8
<b>OPT-2-M3030-20</b>	3	20	10	155	185	66		30	0.5	4.2
<b>OPT-2-M3075-20</b>	4 & 5	20	35	190	223	92		75	0.22	8.6
<b>OPT-2-M3180-00</b>	5 & 6	00	11	360	263	180	400 Max	180	0.09	30
<b>OPT-2-M3300-00</b>	7	00	9	380	310	180		300	0.053	48
<b>OPT-2-M3008-66</b>	1	66	2.5	115	85	74	600 Max	8	2.0	1.7
<b>OPT-2-M3012-66</b>	2	66	2.5	140	110	87		12	1.2	3.2
<b>OPT-2-M3018-66</b>	3	66	10	140	110	87		18	0.9	3.2

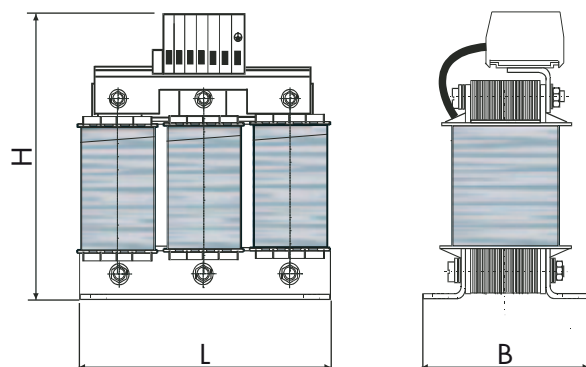

### OPTIFILTER

#### RFI Line Filters

All Optidrive products are manufactured as standard with an internal EMC filter, unless specified by the customer. In general, this internal filter will provide compliance with international standard requirements for the majority of industrial installations and applications.

Where a higher standard of EMC compliance is desired or required, Invertek Drives can provide a range of suitable filters to ensure that an EMC compliant solution for all possible applications can be realised.

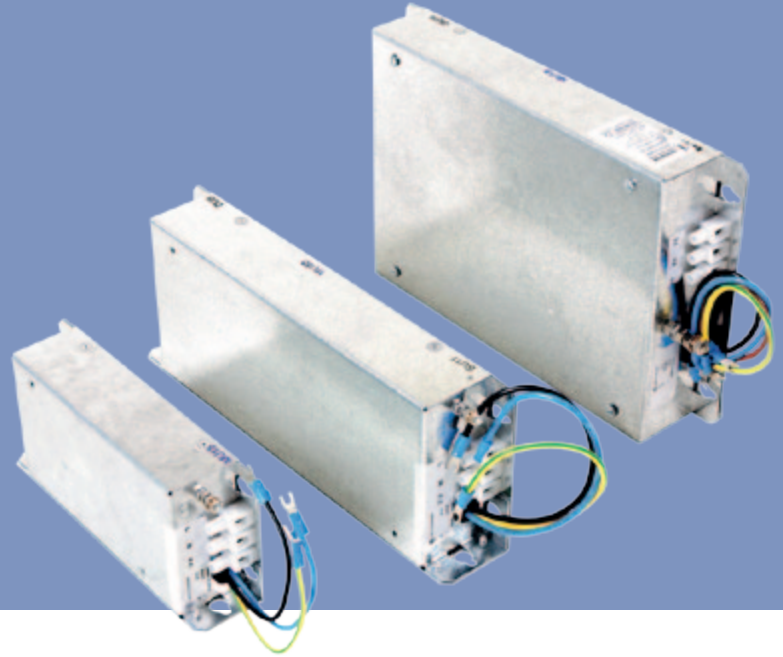

Part Number	Supply Phases	Optidrive Size	Enclosure IP	Length (mm)	Width (mm)	Depth (mm)	Rated Amps	Weight (kg)
<b>OPT-2-E1010-20</b>	1	1	20	180	70	65	10	1.5
<b>OPT-2-E1025-20</b>	1	2	20	250	70	65	25	2.8
<b>OPT-2-E1010-66</b>	1	1	66	180	70	65	10	1.5
<b>OPT-2-E1025-66</b>	1	2	66	250	70	65	25	2.8
<b>OPT-2-E3006-20</b>	3	1	20	210	85	60	6	2.7
<b>OPT-2-E3016-20</b>	3	2	20	230	120	65	16	2.7
<b>OPT-2-E3025-20</b>	3	3	20	230	120	65	25	2.7
<b>OPT-2-E3050-20</b>	3	4	20	115	150	65	50	TBC
<b>OPT-2-E3080-20</b>	3	5	20	373	170	65	80	TBC
<b>OPT-2-E3180-20</b>	3	6	20	470	180	115	180	TBC
<b>OPT-2-E3300-00</b>	3	7	0	660	260	130	300	TBC
<b>OPT-2-E3006-66</b>	3	1	66	210	85	60	6	2.7
<b>OPT-2-E3016-66</b>	3	2	66	230	120	65	16	2.7
<b>OPT-2-E3025-66</b>	3	3	66	200	150	65	25	2.7



## OPTIBRAKE

### Dynamic Braking Resistors

Optibrake dynamic braking resistors are designed specifically for the Optidrive range. For use with high inertia loads which need to be stopped rapidly. Optibrake dynamic braking resistors assist the Optidrive in managing the electrical energy returned from the motor during braking by converting it to heat energy.



Part Number	Optidrive Size	Resistance	Rated Voltage	Rated Power (w)	
				Continuous	Peak
<b>OD-BR100-IN</b>	2, 3	100	900 VDC	200	12000
<b>OD-BRES4-IN</b>	4, 5	22	900 VDC	500	21000

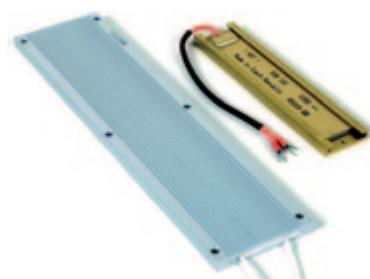

## Local Isolator



Local isolator option allows complete disconnection of the incoming AC power to the drive. The isolator mounts directly to the drive, and provides a local disconnect option. The handle can be padlocked in the off position for safe maintenance.

Part Number	Optidrive Size	H (mm)	W (mm)	D (mm)
<b>OPT-2-ISOLO-S4</b>	4	170	173	80
<b>OPT-2-ISOLO-S5</b>	5	230	235	100

## Through Hole Mount Kit

Through hole mount kits allow optidrive to be mounted through panel, ensuring that the heat from the drives heat sink is kept separate from the control electronics. This allows the optimum panel cooling arrangement to be used, with best possible separation of hot and cold air.

Through panel mounting kits can be used with all frame size 4 and above units.

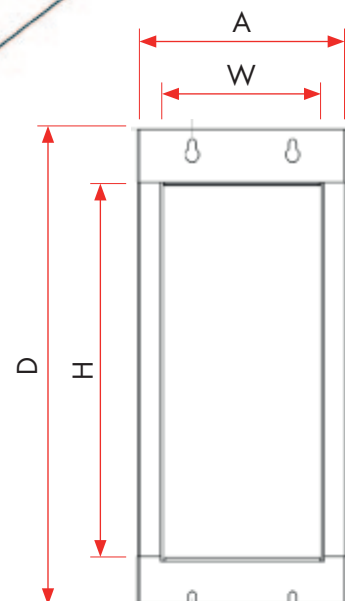
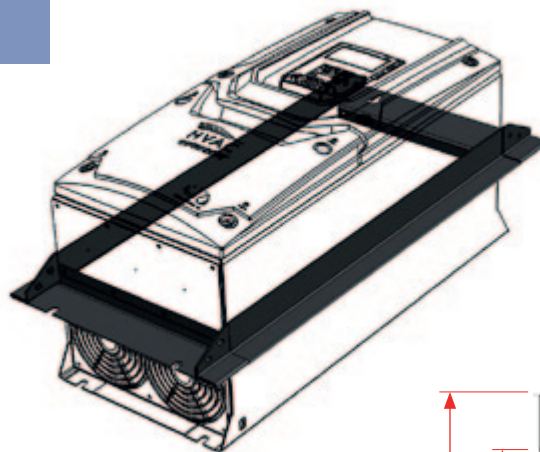

Part Number	Optidrive Size	Panel Cut Out Dimensions		Mount Dimensions	
		H mm (in)	W mm (in)	A mm (in)	D mm (in)
<b>OPT-2-THMT04</b>	4	425 (17.3)	180 (7.09)	228 (8.98)	521.5 (20.53)
<b>OPT-2-THMT05</b>	5	515 (21.26)	240 (9.65)	292 (11.5)	612.5 (24.11)
<b>OPT-2-THMT06</b>	6	815 (34.06)	335 (13.39)	398 (15.67)	924 (36.38)
<b>OPT-2-THMT07</b>	7	1230 (50.4)	335 (13.39)	398 (15.67)	1342 (52.83)

	Product Code	Description	E2	P2	HVAC	Eco	PCE
Remote Keypads	<b>OPT-2-OPPAD-IN</b>	Optipad Remote OLED Keypad with RJ45 Cable	•	•	•	•	
	<b>OPT-2-OPDTK-IN</b>	Optipad with Turkish language support					
	<b>OPT-2-OPORT-IN</b>	Optiport 2 with RJ45 Cable	•	•	•	•	
	<b>OD-OPRTP-IN</b>	Optiport+ Remote Keypad (ODP & VTC) with RJ11 Cable					•
Communication Interfaces	<b>OPT-2-BNTIP-IN</b>	BACnet IP Plug In Interface			•	•	
	<b>OD-DEVNET-IN</b>	DeviceNET External Gateway & Cables	•		•	•	
	<b>OPT-2-DEVNT-IN</b>	DeviceNet Plug In Interface Module		•	•	•	
	<b>OPT-2-ETCAT-IN</b>	EtherCAT Module		•	•	•	
	<b>OPT-2-ETHNT-IN</b>	EtherNet/IP Plug In Interface Module		•	•	•	
	<b>OPT-2-MODIP-IN</b>	Modbus TCP Module		•	•	•	
	<b>OPT-2-PROFB-IN</b>	PROFIBUS DPV-1 Plug In Interface Module		•	•	•	
	<b>OD-PROFB-IN</b>	PROFIBUS External Gateway & Cables	•		•	•	
	<b>OPT-2-PFNET-IN</b>	PROFINET IO Module		•	•	•	
	<b>OPT-2-STICK-IN</b>	Optistick with Bluetooth Interface	•		•	•	
	<b>OD-485AD-IN</b>	USB PC Connection Kit	•	•	•	•	•
I/O Options	<b>OPT-LOGIP-11</b>	110V Logic Input Card	•				
	<b>OPT-LOGIP-23</b>	230V Logic Input Card	•				
	<b>OPT-2-CASCD-IN</b>	Cascade Control Plug In Option Module		•	•	•	
	<b>ODP-2ROUT-IN</b>	Dual Relay Output Card	•				
	<b>OPT-2-ENCOD-IN</b>	Encoder Feedback Plug In Option Module		•			
	<b>OPT-2-EXTIO-IN</b>	Extended I/O Plug In Option Module		•	•	•	
	<b>OPT-2-CANIO-IN</b>	External Remote I/O Interface		•			
	<b>OPT-HVACO-IN</b>	HVACO Drive Running & Tripped Relay Output Card	•				
	<b>OD-LOCMO-IN</b>	Local Test / Control Option Card	•				
	<b>OPT-2-LOCMO-IN</b>	Optidrive P2 / HVAC Local Mouse		•	•	•	
Communications Options	<b>OPT-2-STICK-IN</b>	Optistick with Bluetooth Interface	•	•	•	•	
	<b>OD-485AD-IN</b>	USB PC Connection Kit	•	•	•	•	•
RJ45 Accessories	<b>OPT-2-RJHUB-IN</b>	RJ45 8 Way Network Hub	•	•	•	•	
	<b>OPT-J45SP-IN</b>	RS485 3 Way Data Cable Splitter RJ45	•	•	•	•	
	<b>OPT-J4505-IN</b>	RS485 Data Cable, 0.5M RJ45	•	•	•	•	
	<b>OPT-J4510-IN</b>	RS485 Data Cable, 1.0M RJ45	•	•	•	•	
	<b>OPT-J4530-IN</b>	RS485 Data Cable, 3.0M RJ45	•	•	•	•	
Input Chokes	<b>OPT-2-L1016-20</b>	Input Choke, 1 Phase, 16 Amp, IP20	•	•	•	•	
	<b>OPT-2-L1016-66</b>	Input Choke, 1 Phase, 16 Amp, IP66	•	•	•	•	
	<b>OPT-2-L1025-20</b>	Input Choke, 1 Phase, 25 Amp, IP20	•	•	•	•	
	<b>OPT-2-L1025-66</b>	Input Choke, 1 Phase, 25 Amp, IP66	•	•	•	•	
	<b>OPT-2-L1035-20</b>	Input Choke, 1 Phase, 35 Amp, IP20	•	•	•	•	
	<b>OPT-2-L3010-20</b>	Input Choke, 3 Phase, 10 Amp, IP20	•	•	•	•	
	<b>OPT-2-L3010-66</b>	Input Choke, 3 Phase, 10 Amp, IP66	•	•	•	•	
	<b>OPT-2-L3018-66</b>	Input Choke, 3 Phase, 18 Amp, IP66	•	•	•	•	
	<b>OPT-2-L3200-00</b>	Input Choke, 3 Phase, 200 Amp, IP00	•	•	•	•	
	<b>OPT-2-L3300-00</b>	Input Choke, 3 Phase, 300 Amp, IP00	•	•	•	•	
	<b>OPT-2-L3036-20</b>	Input Choke, 3 Phase, 36 Amp, IP20	•	•	•	•	
	<b>OPT-2-L3050-20</b>	Input Choke, 3 Phase, 50 Amp, IP20	•	•	•	•	
	<b>OPT-2-L3006-20</b>	Input Choke, 3 Phase, 6 Amp, IP20	•	•	•	•	
	<b>OPT-2-L3006-66</b>	Input Choke, 3 Phase, 6 Amp, IP66	•	•	•	•	
	<b>OPT-2-L3090-20</b>	Input Choke, 3 Phase, 90 Amp, IP20	•	•	•	•	
	Output Filters	<b>OPT-2-M3012-20</b>	Output Filter, 12 Amp, IP20	•	•	•	•
<b>OPT-2-M3012-66</b>		Output Filter, 12 Amp, IP66	•	•	•	•	
<b>OPT-2-M3018-66</b>		Output Filter, 18 Amp, IP66	•	•	•	•	
<b>OPT-2-M3180-20</b>		Output Filter, 180 Amp, IP20	•	•	•	•	
<b>OPT-2-M3030-20</b>		Output Filter, 30 Amp, IP20	•	•	•	•	
<b>OPT-2-M3300-00</b>		Output Filter, 300 Amp, IP00	•	•	•	•	
<b>OPT-2-M3048-20</b>		Output Filter, 48 Amp, IP20	•	•	•	•	
<b>OPT-2-M3075-20</b>		Output Filter, 75 Amp, IP20	•	•	•	•	
<b>OPT-2-M3008-20</b>		Output Filter, 8 Amp, IP20	•	•	•	•	
<b>OPT-2-M3008-66</b>		Output Filter, 8 Amp, IP66	•	•	•	•	
External EMC Filters		<b>OPT-2-E1010-20</b>	Optifilter EMC Input Filter, 1 Phase, 10 Amp, IP20	•	•	•	•
	<b>OPT-2-E1010-66</b>	Optifilter EMC Input Filter, 1 Phase, 10 Amp, IP66	•	•	•	•	
	<b>OPT-2-E1025-20</b>	Optifilter EMC Input Filter, 1 Phase, 25 Amp, IP20	•	•	•	•	
	<b>OPT-2-E1025-66</b>	Optifilter EMC Input Filter, 1 Phase, 25 Amp, IP66	•	•	•	•	
	<b>OPT-2-E3016-20</b>	Optifilter EMC Input Filter, 3 Phase, 16 Amp, IP20	•	•	•	•	
	<b>OPT-2-E3016-66</b>	Optifilter EMC Input Filter, 3 Phase, 16 Amp, IP66	•	•	•	•	
	<b>OPT-2-E3180-20</b>	Optifilter EMC Input Filter, 3 Phase, 180 Amp, IP20	•	•	•	•	
	<b>OPT-2-E3025-20</b>	Optifilter EMC Input Filter, 3 Phase, 25 Amp, IP20	•	•	•	•	
	<b>OPT-2-E3025-66</b>	Optifilter EMC Input Filter, 3 Phase, 25 Amp, IP66	•	•	•	•	
	<b>OPT-2-E3300-00</b>	Optifilter EMC Input Filter, 3 Phase, 300 Amp, IP00	•	•	•	•	
	<b>OPT-2-E3050-20</b>	Optifilter EMC Input Filter, 3 Phase, 50 Amp, IP20	•	•	•	•	
	<b>OPT-2-E3006-20</b>	Optifilter EMC Input Filter, 3 Phase, 6 Amp, IP20	•	•	•	•	
	<b>OPT-2-E3006-66</b>	Optifilter EMC Input Filter, 3 Phase, 6 Amp, IP66	•	•	•	•	
	<b>OPT-2-E3080-20</b>	Optifilter EMC Input Filter, 3 Phase, 80 Amp, IP20	•	•	•	•	
Braking Resistors	<b>OPT-BR050-IN-I55</b>	Brake Resistor, IP55, Size 2, 200W, 50R	•	•			
	<b>OD-BR100-IN</b>	Brake Resistor, Size 2, 100R, 200W	•				
	<b>OD-BRE54-IN</b>	Brake Resistor, Size 4, 33R, 500W		•			
Local Isolator	<b>OPT-2-ISOLO-S4</b>	Local Isolator, Frame Size 4		•	•	•	
	<b>OPT-2-ISOLO-S5</b>	Local Isolator, Frame Size 5		•	•	•	
Through Hole Mount Kit	<b>OPT-2-THMT04</b>	Through Hole Mount Kit Frame Size 4		•	•	•	
	<b>OPT-2-THMT05</b>	Through Hole Mount Kit Frame Size 5		•	•	•	
	<b>OPT-2-THMT06</b>	Through Hole Mount Kit Frame Size 6		•	•	•	
	<b>OPT-2-THMT07</b>	Through Hole Mount Kit Frame Size 7		•	•	•	
Demonstration Case	<b>OD-DEMOC-IN</b>	Demonstration Case - ODE-2 IP20 & IP66					

**Inverterk Drives Ltd** is dedicated to the design, manufacture and marketing of electronic variable speed drives. The state of the art UK headquarters houses specialist facilities for research & development, manufacturing and global marketing. The company pledges to implement and operate the ISO 14001 Environmental Management System to enhance environmental performance.

All company operations are accredited to the exacting customer focused ISO 9001:2008 quality standard. The company's products are sold globally in over 80 different countries. Inverterk Drives' unique and innovative drives are designed for ease of use and meet with recognised international design standards.



UK Headquarters, Welshpool

## Global Drive Solutions

Inverterk Drives operate at the heart of automated systems around the world



### Crane Control

Demanding application at South African mine

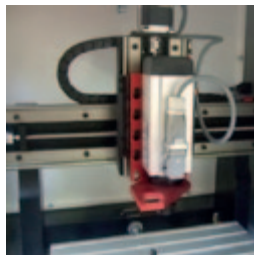

### Machine Tool OEM

UK machine tool supplier specifies Optidrive



### Manufacturing

IP66 washdown duty drives in Singapore



### Food Processing

Precision conveyor control in Spain



### Amusement Parks

Reliable control of difficult loads in Spain

Inverterk Drives Ltd adopts a policy of continuous improvement and whilst every effort has been made to provide accurate and up to date information, the information contained in this catalogue should be used for guidance purposes only and does not form part of any contract.

No part of this catalogue may be reproduced or transmitted in any form or by any means, electrical or mechanical including photocopying, recording or by any other form of information storage or retrieval system without permission in writing from the publisher.

**INVERTEK DRIVES LIMITED** UK Headquarters

Offa's Dyke Business Park, Welshpool, Powys. UK SY21 8JF

Tel: +44 (0)1938 556868 Fax: +44 (0)1938 556869 Email: sales@inverterkdrives.com



©2014 Inverterk Drives Ltd. All rights reserved.

85-IDLBR-01 V6.01