

IF IN DOUBT - ASK

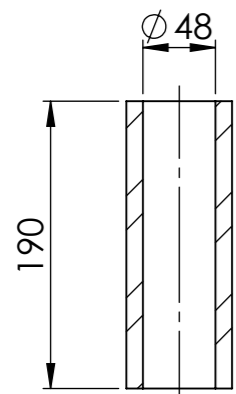

OUTPUT SHAFT

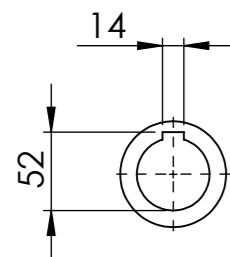
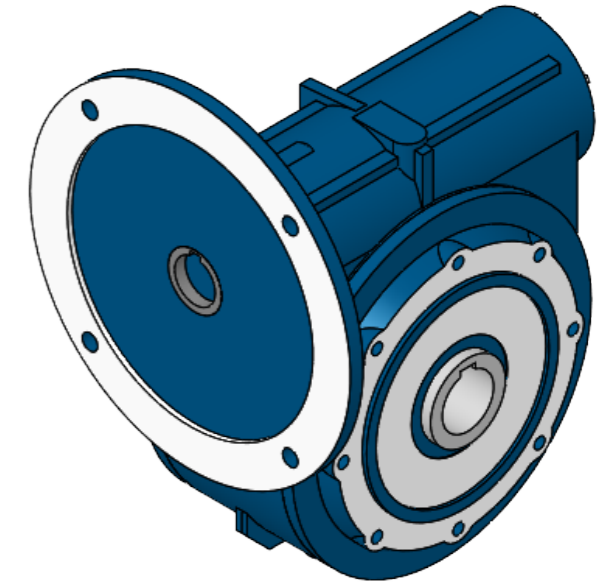
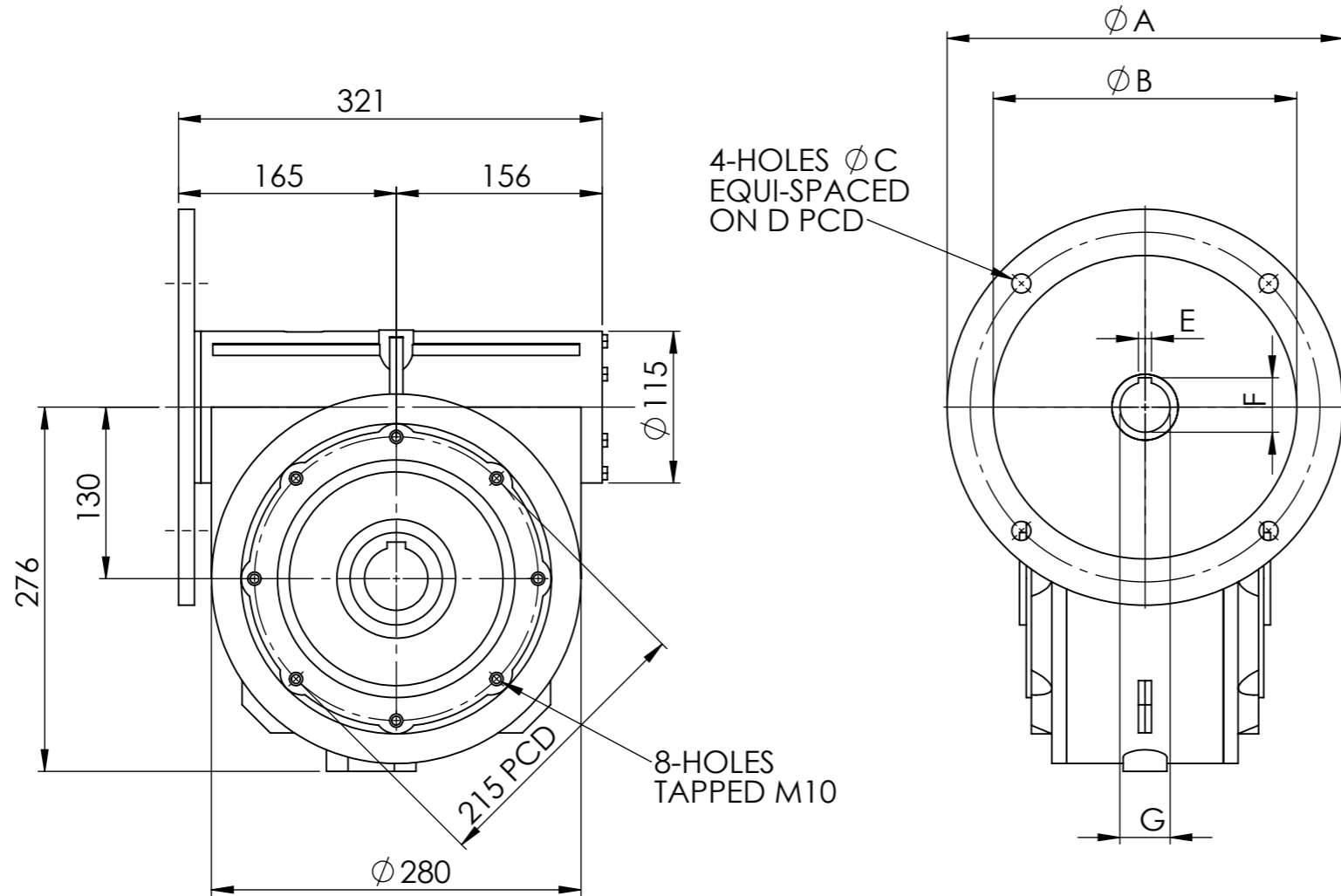
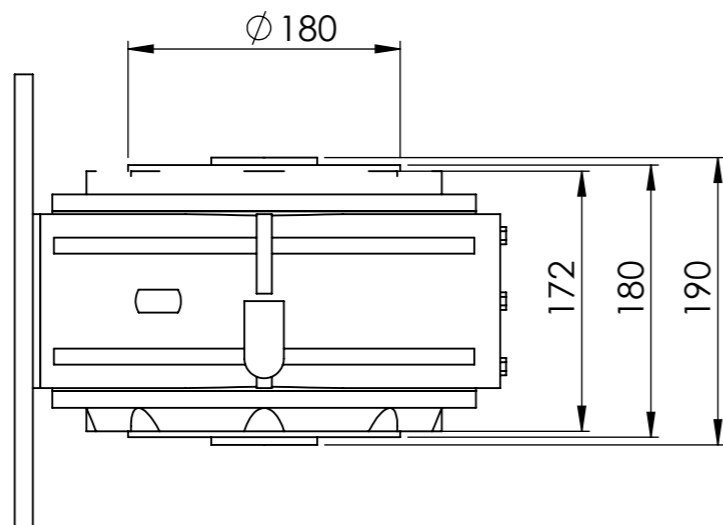

RATIO	MOTOR			
	90	100	112	132
7.5	/(*)	/	/	/
10	/(*)	/	/	/
15	/(*)	/	/	/
20	/(*)	/	/	/
25	/(*)	/	/	/
30	/(*)	/	/	/
40	/(*)	/	/	/
50	/(*)	/	/	/
60	/	/	/	/
80	/	/	/	/
100	/	/	/	/

(\*) REQUIRES MOUNTING BUSH

INPUT FLANGE DIMENSIONS

	A	B	C	D	E	F	G
90 B5	200	130	12	165	6	27	24
90 B14	140	95	7	115	6	27	24
100 B5	250	180	14	215	8	31	28
100 B14	160	110	10	130	8	31	28
112 B5	250	180	14	215	8	31	28
112 B14	160	110	10	130	8	31	28
132 B5	300	230	15	265	10	41	38



**ELECTRIC MOTORS & GEARBOXES LTD**

ASHMORE LAKE INDUSTRIAL ESTATE, WILLENHALL, WEST MIDLANDS, WV12 4LH  
 PHONE 01902 601403, FAX 01902 601408.  
 E MAIL sales @emag-ltd.co.uk

THIS DRAWING IN DESIGN & DETAIL IS THE PROPERTY OF EMAG LTD AND IS INTENDED SOLELY FOR THE USE OF THE PERSON OR COMPANY TO WHOM IT IS ISSUED. IN NO EVENT SHALL IT BE COPIED OR LOANED WITHOUT THE EXPRESS PERMISSION OF EMAG LTD

© ELECTRIC MOTORS & GEARBOXES LTD		FIRST ANGLE PROJECTION	
TITLE <b>MI 130</b>		CLIENT	
DRAWN R SPENCER	SCALE <b>1:5</b> (A3)	DRG No <b>MI130 GEAR UNIT</b>	
DATE			