

IF IN DOUBT - ASK

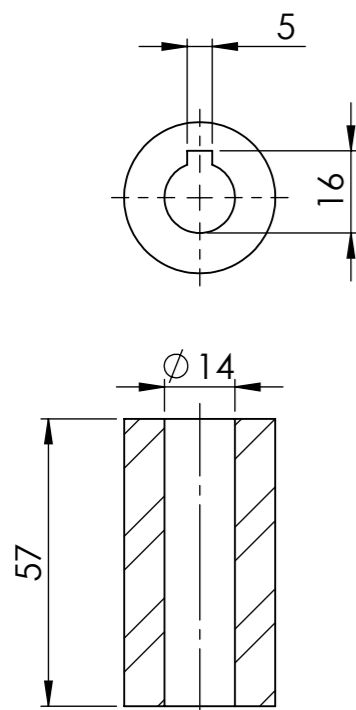
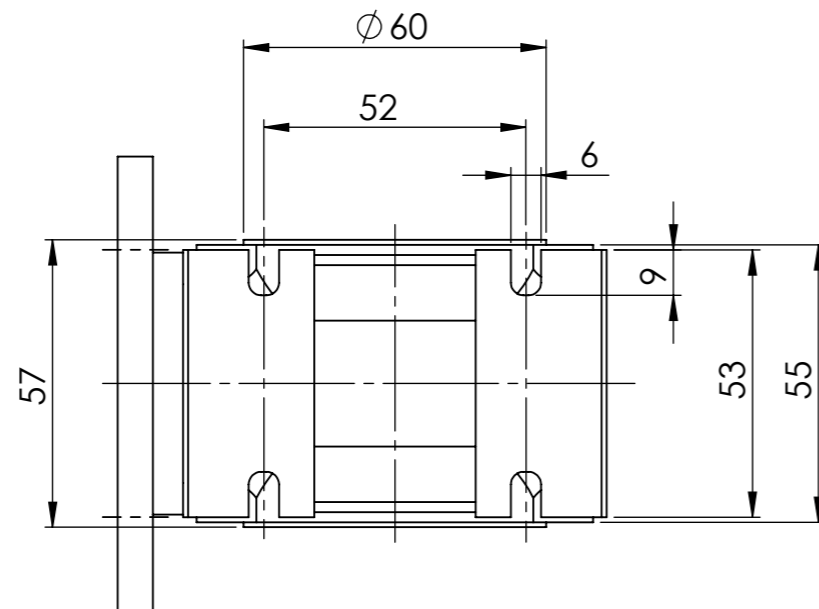
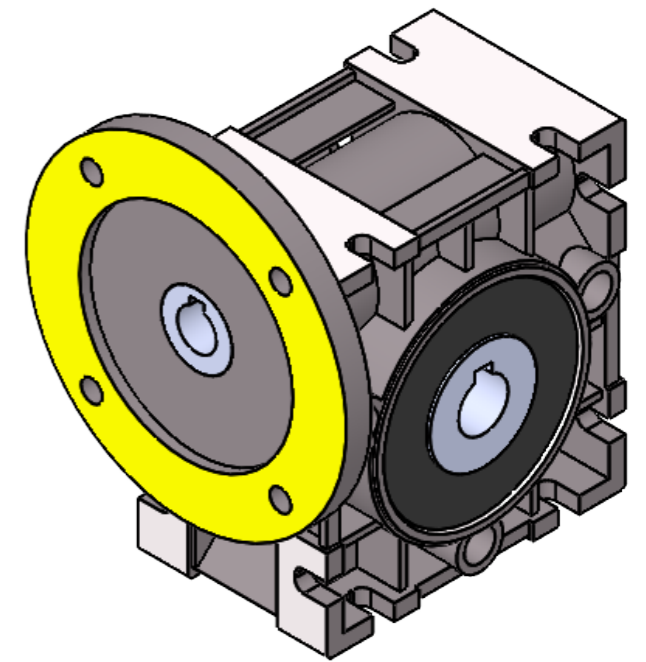
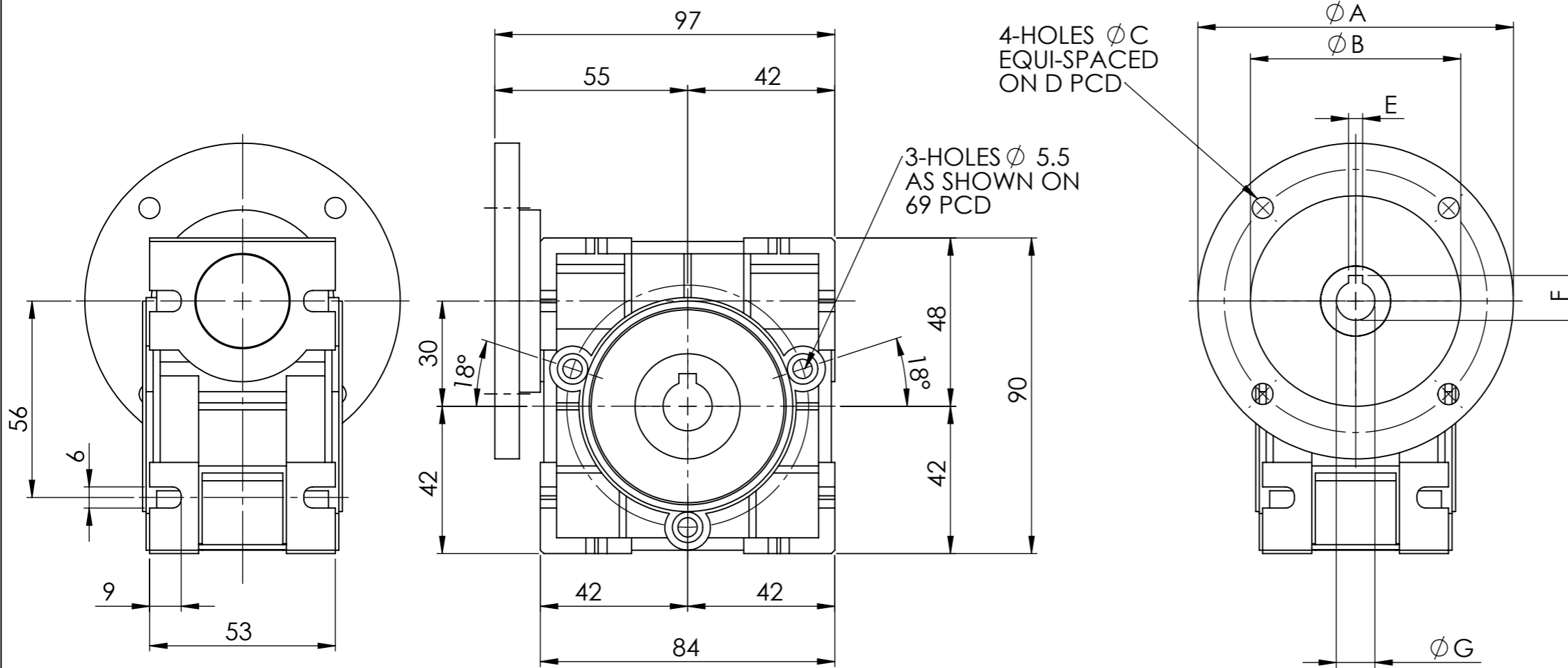

OUTPUT SHAFT

RATIO	MOTOR		
	56	63	71
7.5	/	/	
10	/	/	
15	/	/	
20	/	/	
25	/	/	
30	/	/	
40	/		
50	/		
60	/		
80	/		
100	/		

INPUT FLANGE DIMENSIONS							
	A	B	C	D	E	F	G
56 B5	120	80	7	100	3	10.2	9
56 B14	80	50	6	65	3	10.2	9
63 B5	140	95	10	115	4	12.8	11
63 B14	90	60	6	75	4	12.8	11

EMAG ELECTRIC MOTORS & GEARBOXES LTD
 ASHMORE LAKE INDUSTRIAL ESTATE, WILLENHALL, WEST MIDLANDS, WV12 4LH
 PHONE 01902 601403, FAX 01902 601408.
 E MAIL sales @emag-ltd.co.uk

THIS DRAWING IN DESIGN & DETAIL IS THE PROPERTY OF EMAG LTD AND IS INTENDED SOLELY FOR THE USE OF THE PERSON OR COMPANY TO WHOM IT IS ISSUED. IN NO EVENT SHALL IT BE COPIED OR LOANED WITHOUT THE EXPRESS PERMISSION OF EMAG LTD

© ELECTRIC MOTORS & GEARBOXES LTD FIRST ANGLE PROJECTION

TITLE MI 30 CLIENT

DRAWN R SPENCER SCALE 1:1.5 (A3) DRG No

DATE MI30 GEAR UNIT