

IF IN DOUBT - ASK

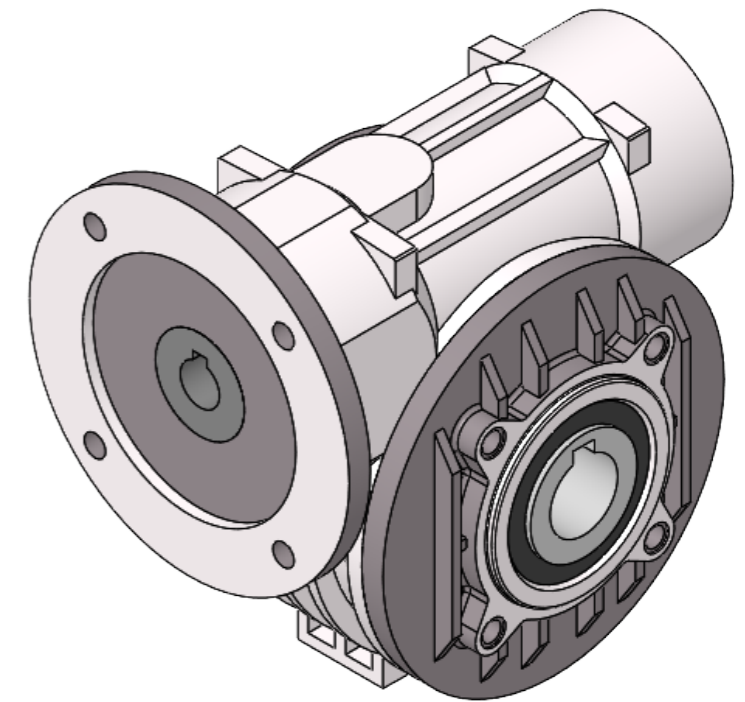

INPUT FLANGE DIMENSIONS							
	A	B	C	D	E	F	G
56 B5	120	80	7	100	3	10.2	9
56 B14	80	50	6	65	3	10.2	9
63 B5	140	95	10	115	4	12.8	11
63 B14	90	60	6	75	4	12.8	11
71 B5	160	110	10	130	5	16.2	14
71 B14	105	70	7	85	5	16.2	14

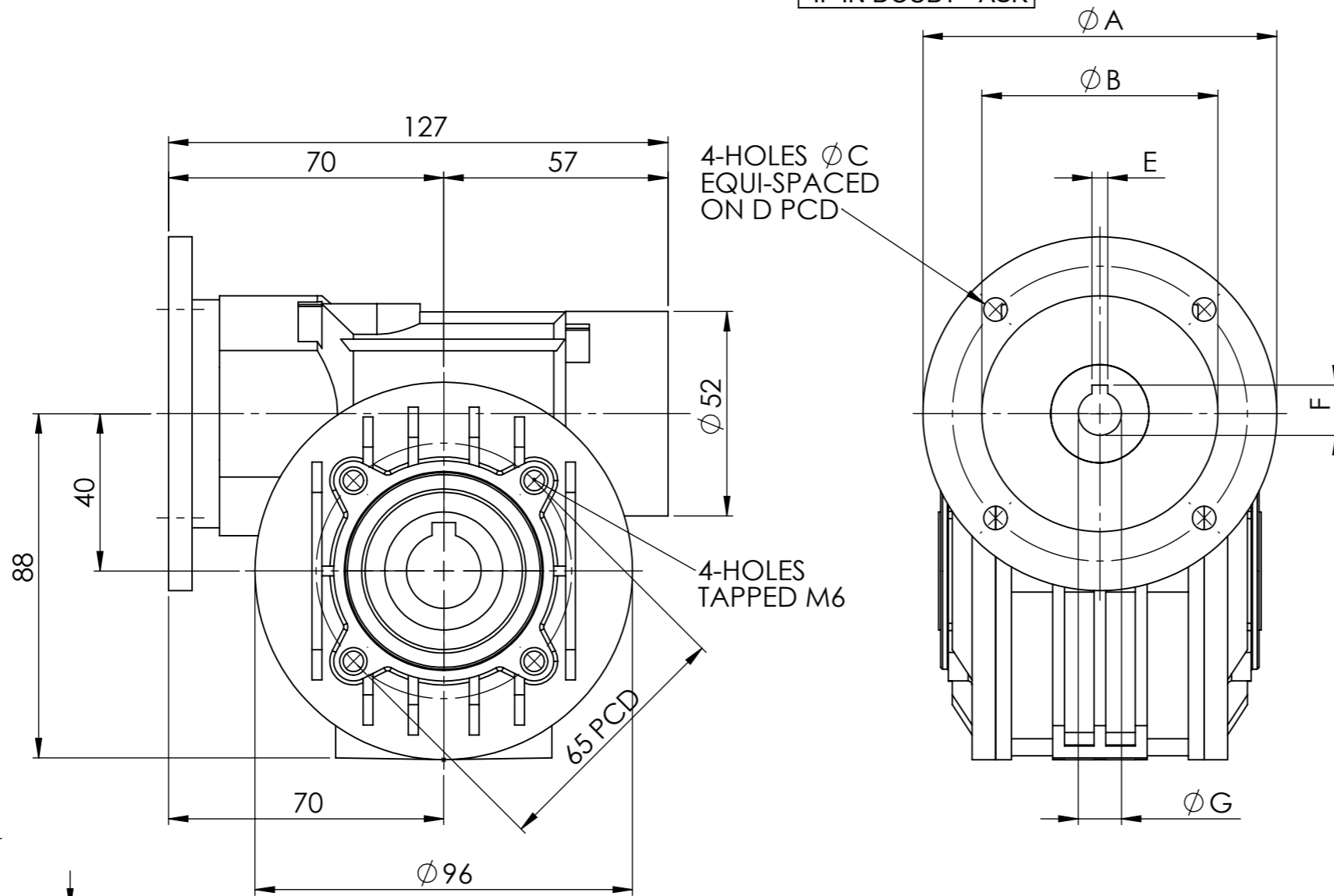
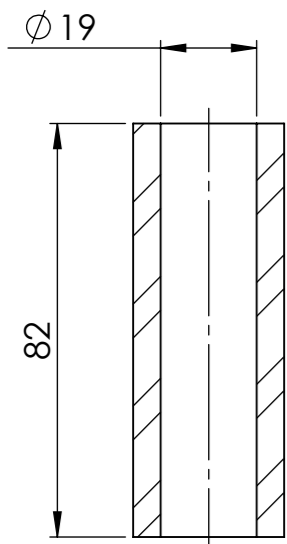
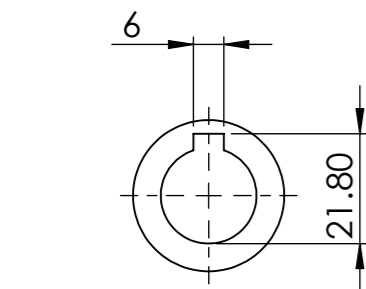

OUTPUT SHAFT

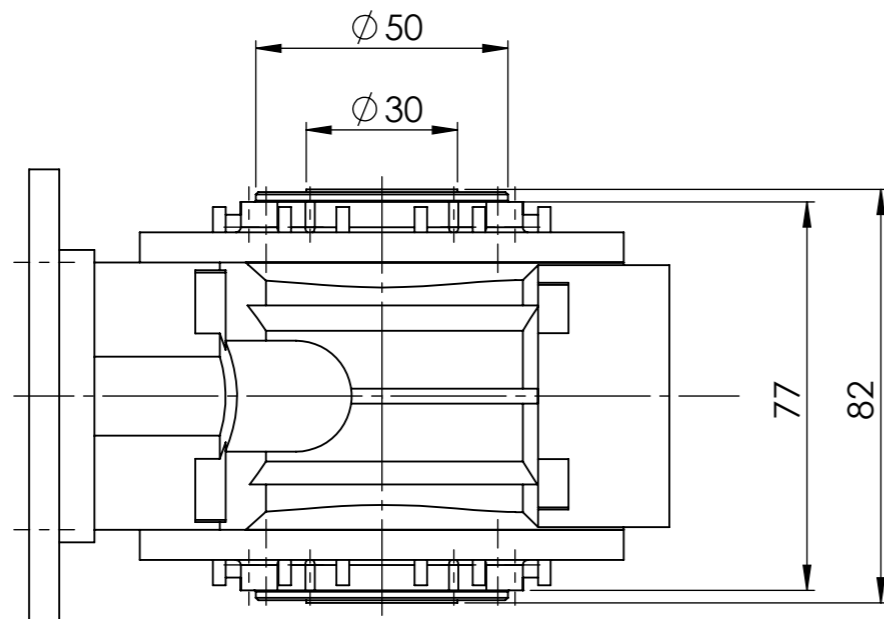

RATIO	MOTOR		
	56	63	71
7.5	/(*)	/	/
10	/(*)	/	/
15	/(*)	/	/
20	/(*)	/	/
25	/(*)	/	/
30	/(*)	/	/
40	/(*)	/	/
50	/(*)	/	/
60	/	/	/
80	/	/	/
100	/	/	/

(*) REQUIRES MOUNTING BUSH

		ELECTRIC MOTORS & GEARBOXES LTD ASHMORE LAKE INDUSTRIAL ESTATE, WILLENHALL, WEST MIDLANDS, WV12 4LH PHONE 01902 601403, FAX 01902 601408. E MAIL sales @emag-ltd.co.uk	
		THIS DRAWING IN DESIGN & DETAIL IS THE PROPERTY OF EMAG LTD AND IS INTENDED SOLELY FOR THE USE OF THE PERSON OR COMPANY TO WHOM IT IS ISSUED. IN NO EVENT SHALL IT BE COPIED OR LOANED WITHOUT THE EXPRESS PERMISSION OF EMAG LTD	
© ELECTRIC MOTORS & GEARBOXES LTD		FIRST ANGLE PROJECTION	
TITLE MI 40		CLIENT	
DRAWN R SPENCER	SCALE 1:1.5 (A3)	DRG No	MI40 GEAR UNIT
DATE			