

# SITI SPA MI50

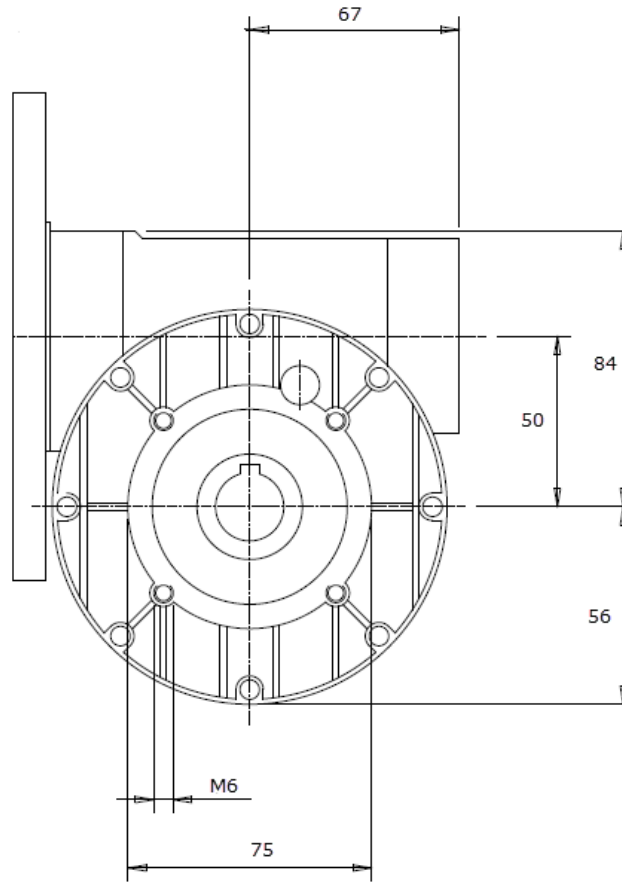

A

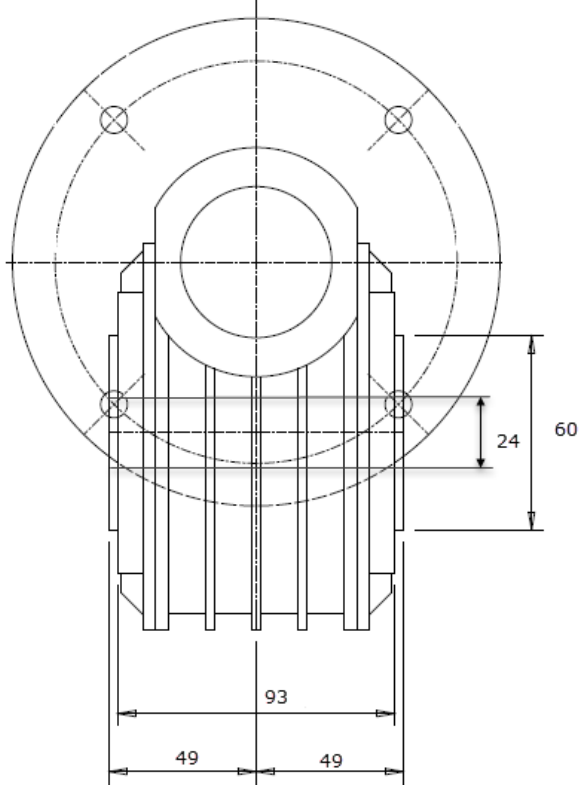
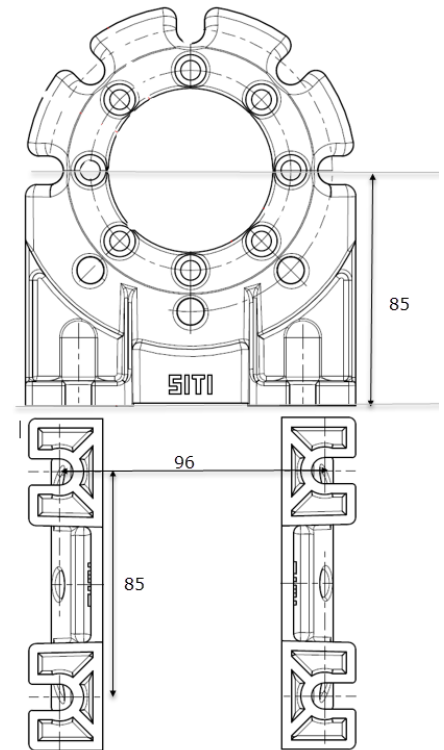

PAM	⊕	56	63	71	80	90	100	112	132	160	180	200
	B5	9/120	11/140	14/160	19/200	24/200	28/250	28/250	38/300	42/350	48/350	55/400
	B14	9/80	11/90	14/105	19/120	24/140	28/160	28/160				