

IF IN DOUBT - ASK

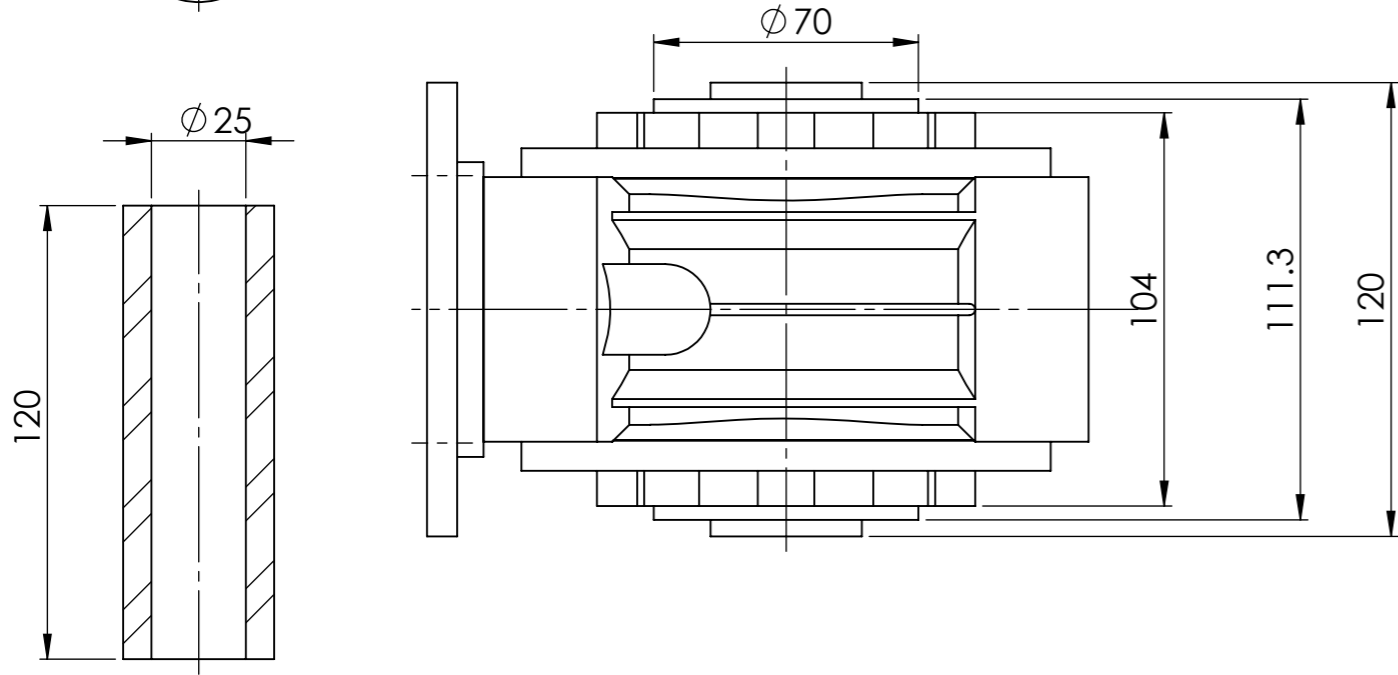
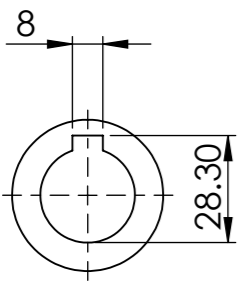
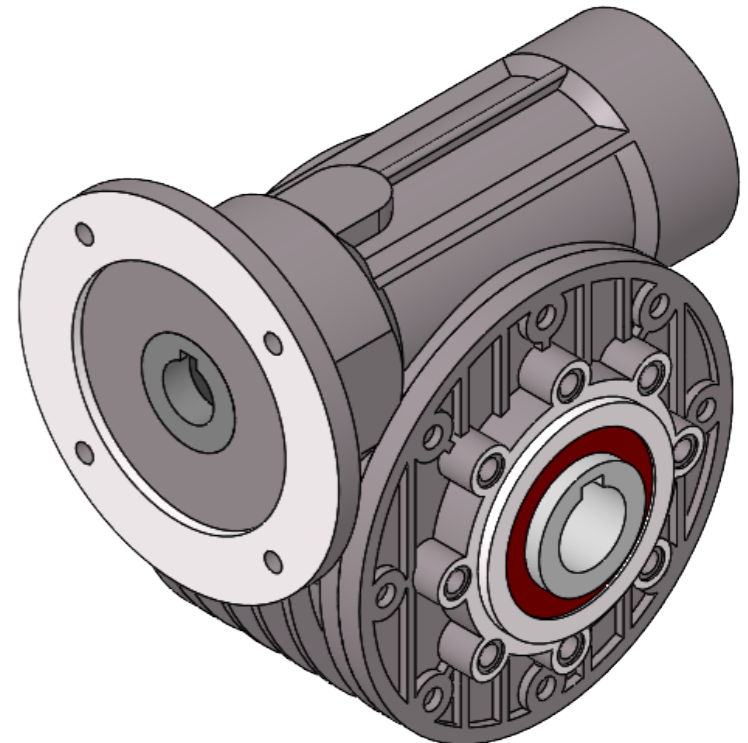
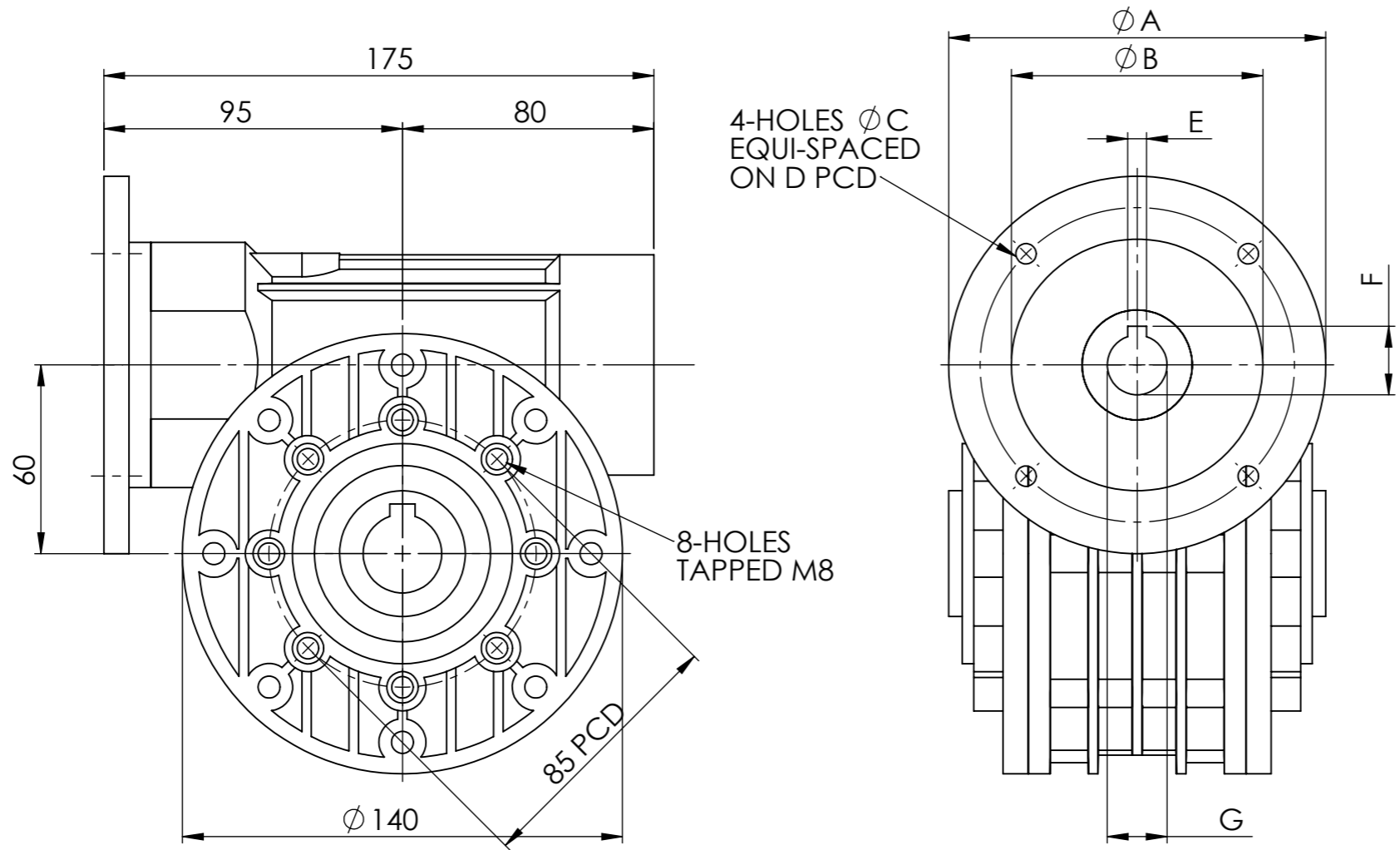

OUTPUT SHAFT

INPUT FLANGE DIMENSIONS							
	A	B	C	D	E	F	G
71 B5	160	110	10	130	5	16.2	14
71 B14	105	70	7	85	5	16.2	14
80 B5	200	130	12	165	6	21.5	19
80 B14	120	80	7	100	6	21.5	19
90 B5	200	130	12	165	6	27	24
90 B14	140	95	7	115	6	27	24

RATIO	MOTOR		
	71	80	90
7.5	/(*)	/	/
10	/(*)	/	/
15	/(*)	/	/
20	/(*)	/	/
25	/(*)	/	/
30	/(*)	/	/
40	/(*)	/	/
50	/(*)	/	
60	/	/	
80	/	/	
100	/	/	

(*) REQUIRES MOUNTING BUSH

ELECTRIC MOTORS & GEARBOXES LTD
 ASHMORE LAKE INDUSTRIAL ESTATE, WILLENHALL, WEST MIDLANDS, WV12 4LH
 PHONE 01902 601403, FAX 01902 601408.
 E MAIL sales@emag-ltd.co.uk

THIS DRAWING IN DESIGN & DETAIL IS THE PROPERTY OF EMAG LTD AND IS INTENDED SOLELY FOR THE USE OF THE PERSON OR COMPANY TO WHOM IT IS ISSUED. IN NO EVENT SHALL IT BE COPIED OR LOANED WITHOUT THE EXPRESS PERMISSION OF EMAG LTD

© ELECTRIC MOTORS & GEARBOXES LTD		FIRST ANGLE PROJECTION	
TITLE MI 60		CLIENT	
DRAWN R SPENCER	SCALE 1:2 (A3)	DRG No	MI60 GEAR UNIT
DATE			