

IF IN DOUBT - ASK

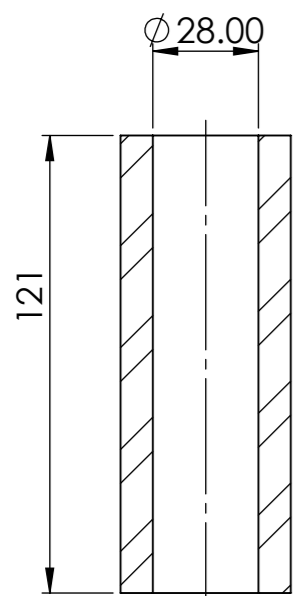

OUTPUT SHAFT

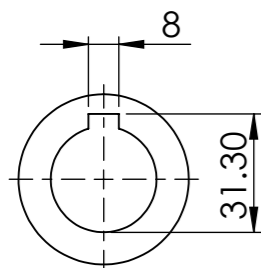
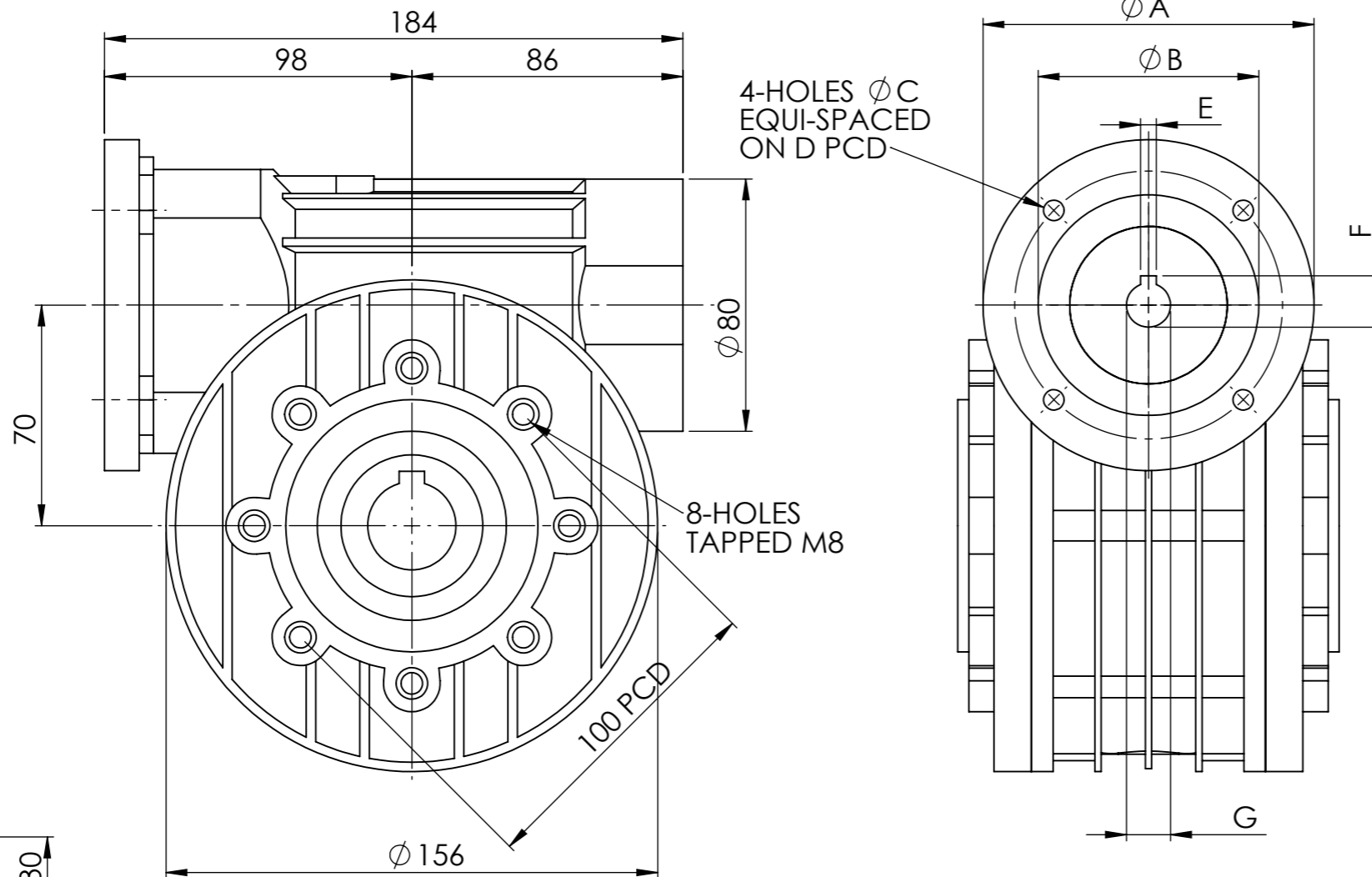
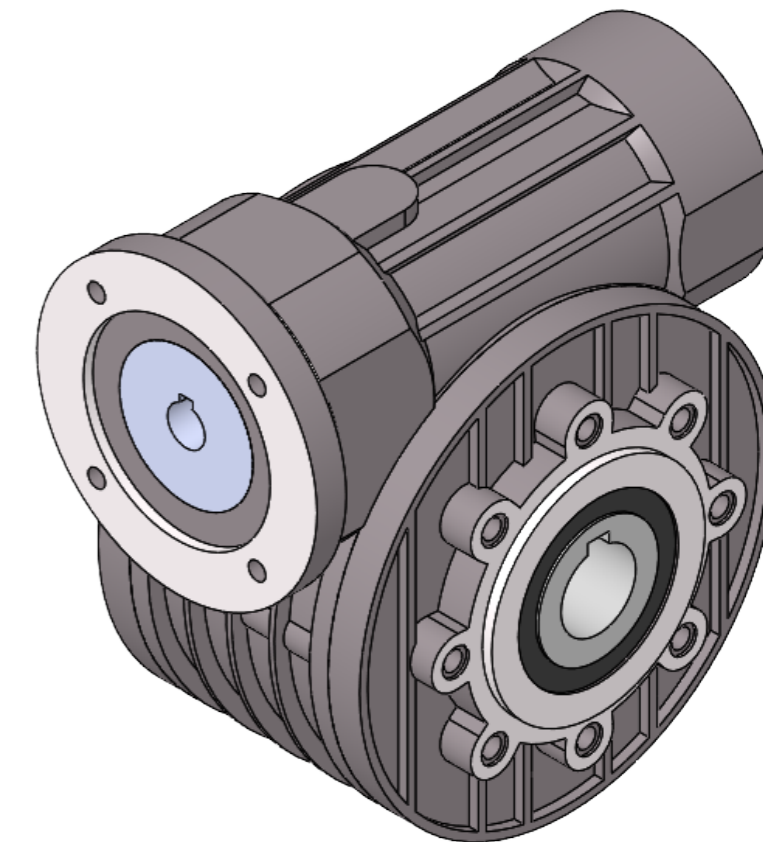
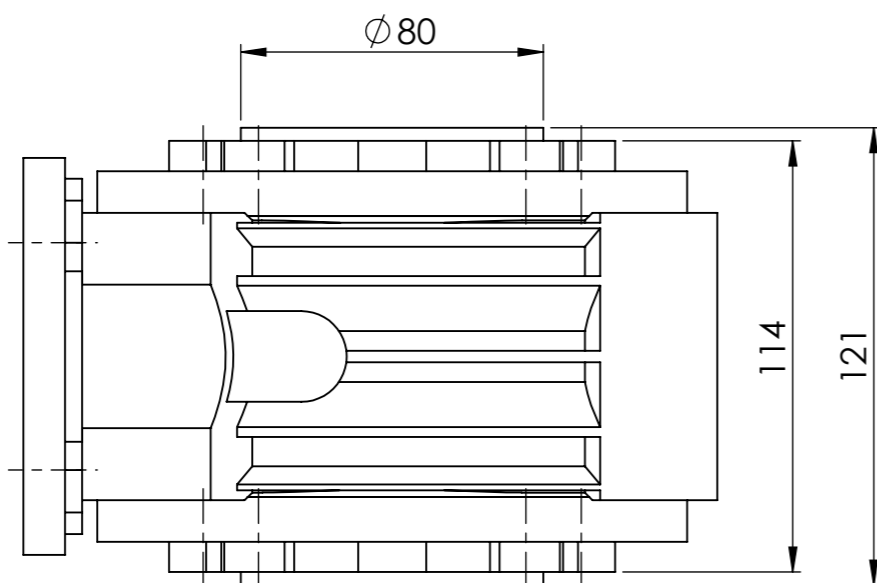

INPUT FLANGE DIMENSIONS							
	A	B	C	D	E	F	G
71 B5	160	110	10	130	5	16.2	14
71 B14	105	70	7	85	5	16.2	14
80 B5	200	130	12	165	6	21.5	19
80 B14	120	80	7	100	6	21.5	19
90 B5	200	130	12	165	6	27	24
90 B14	140	95	7	115	6	27	24
100 B5	250	180	14	215	8	31	28
100 B14	160	110	10	130	8	31	28

RATIO	MOTOR			
	71	80	90	100
7.5	/(*)	/	/	/
10	/(*)	/	/	/
15	/(*)	/	/	/
20	/(*)	/	/	
25	/(*)	/	/	
30	/(*)	/	/	
40	/(*)	/	/	
50	/(*)	/		
60	/	/		
80	/	/		
100	/	/		

(*) REQUIRES MOUNTING BUSH

		ELECTRIC MOTORS & GEARBOXES LTD ASHMORE LAKE INDUSTRIAL ESTATE, WILLENHALL, WEST MIDLANDS, WV12 4LH PHONE 01902 601403, FAX 01902 601408. E MAIL sales @emag-ltd.co.uk	
		THIS DRAWING IN DESIGN & DETAIL IS THE PROPERTY OF EMAG LTD AND IS INTENDED SOLELY FOR THE USE OF THE PERSON OR COMPANY TO WHOM IT IS ISSUED. IN NO EVENT SHALL IT BE COPIED OR LOANED WITHOUT THE EXPRESS PERMISSION OF EMAG LTD	
© ELECTRIC MOTORS & GEARBOXES LTD		FIRST ANGLE PROJECTION	
TITLE MI 70		CLIENT	
DRAWN R SPENCER	SCALE 1:2 (A3)	DRG No	MI70 GEAR UNIT
DATE			