

MNHL 25 PAM - MOTORIDUTTORE P.A.M.

**MNHL 25 PAM - ARRANGED GEARED MOTORS**

*MNHL 25 PAM - GETRIEBE ZUM I.E.C. MOTORANBAU*

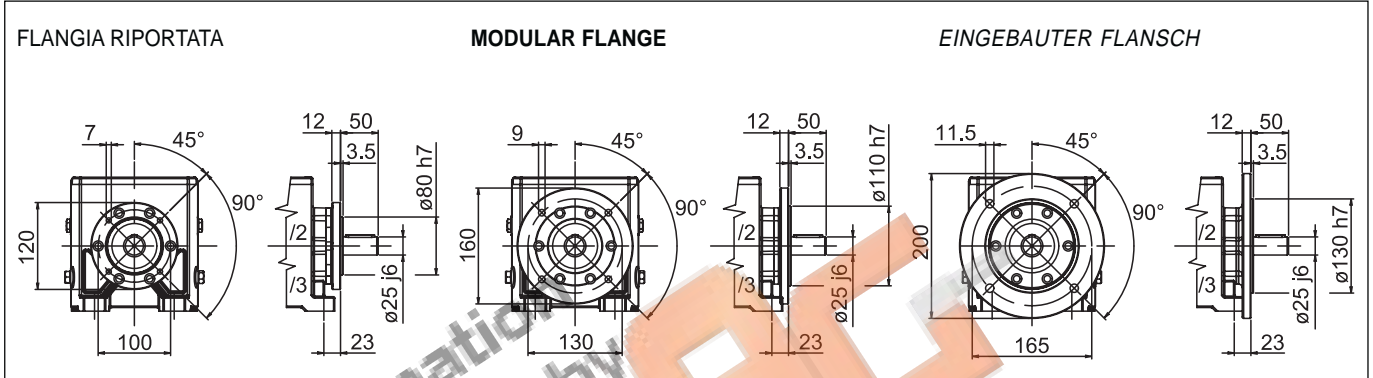
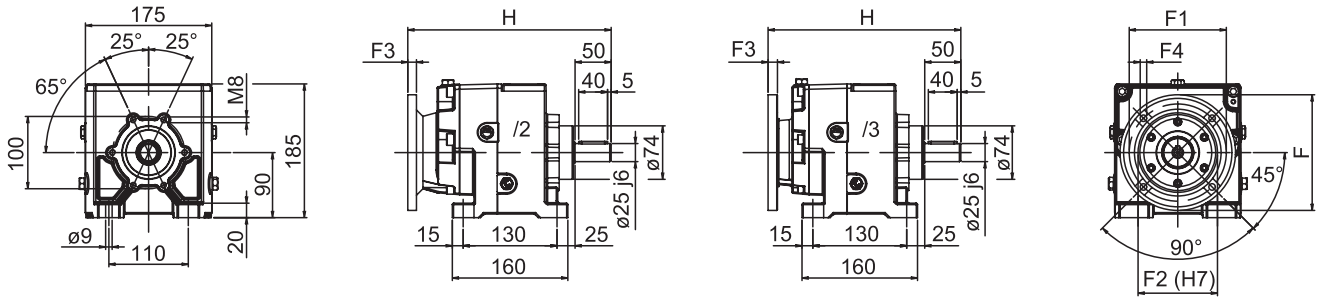

Nota: Disponibile anche con albero uscita ø 24 j6 mm.

**Note: Even available with 24 j6 mm shaft.**

Bemerkung: Verfügbar auch 24 j6 mm welle.

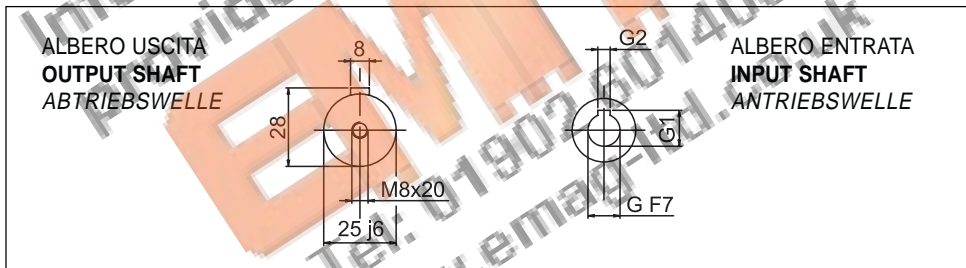

25/2 - 25/3	G	G1	G2	F	F1	F2	F3	F4	H
/2 ... 63 B5	11	12,5	4	140	115	95	12	9	276
/2F ... 63 B5									
/2 ... 71 B5	14	16,3	5	160	130	110	10	9	282
/2F ... 71 B5									
/2 ... 80 B5	19	21,8	6	200	165	130	11	11	276
/2F ... 80 B5									
/2 ... 90 B5	24	27,3	8	200	165	130	11	11	276
/2F ... 90 B5									
/2 ... 100-112 B5	28	31,3	8	250	215	180	13	13	276
/2F ... 100-112 B5									
/3 ... 56 B5	9	10,4	3	120	100	80	8	7	269
/3F ... 56 B5									
/3 ... 63 B5	11	12,8	4	140	115	95	12	9	268
/3F ... 63 B5									
/3 ... 71 B5	14	16,3	5	160	130	110	10,5	9	267
/3F ... 71 B5									