

IF IN DOUBT - ASK

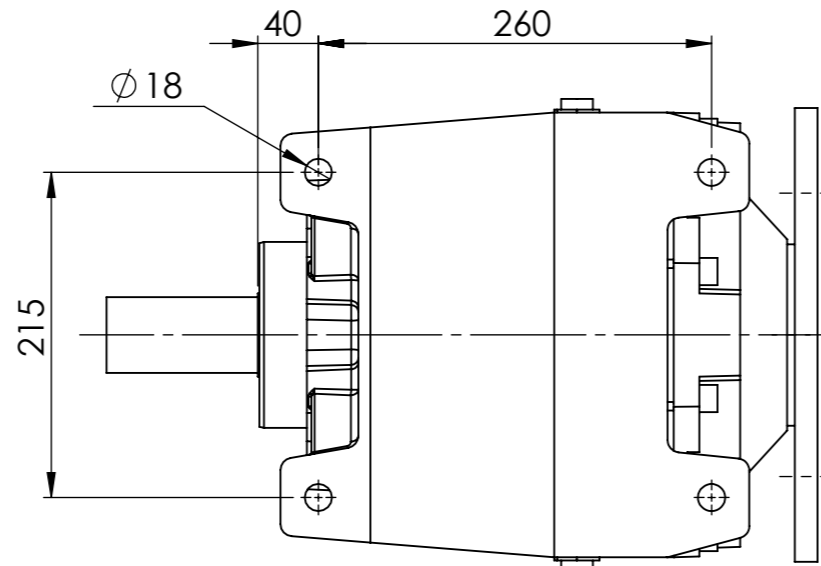

INPUT FLANGE DIMENSIONS									
	A	B	C	D	E	F	G	H	I
63 B5	140	95	10	115	4	12.8	11	447	7.5
71 B5	160	110	10	130	5	16.2	14	453	12
71 B14	105	70	7	85	5	16.2	14		
80 B5	200	130	12	165	6	21.5	19	447	13.5
80 B14	120	80	7	100	6	21.5	19		
90 B5	200	130	12	165	6	27.3	24	447	13.5
90 B14	140	95	7	115	6	27.3	24		
100/112 B5	250	180	14	215	8	31.3	28	450	16
100 /112 B14	160	110	10	130	8	31.3	28		

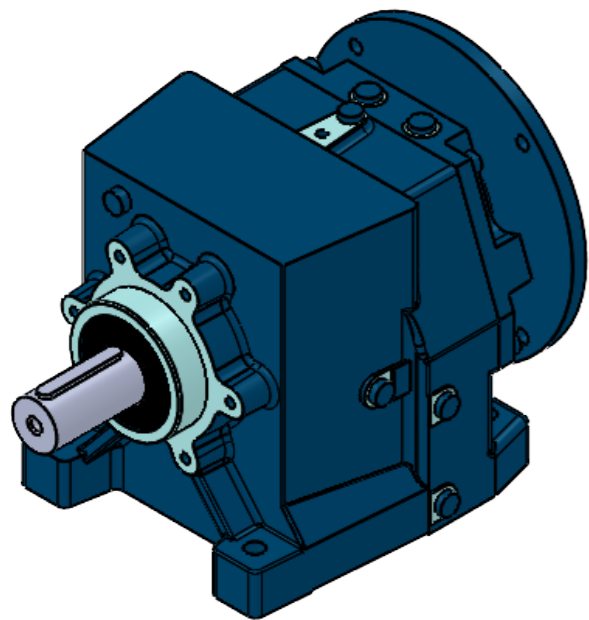
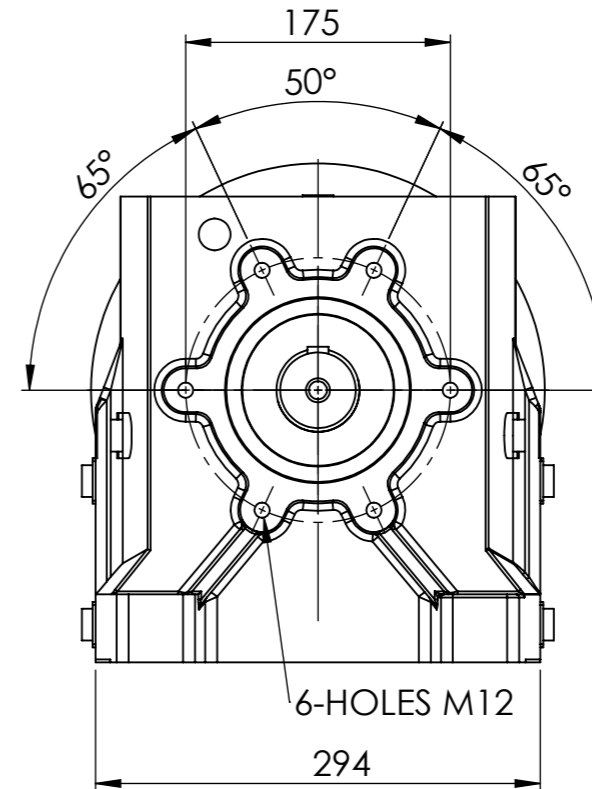
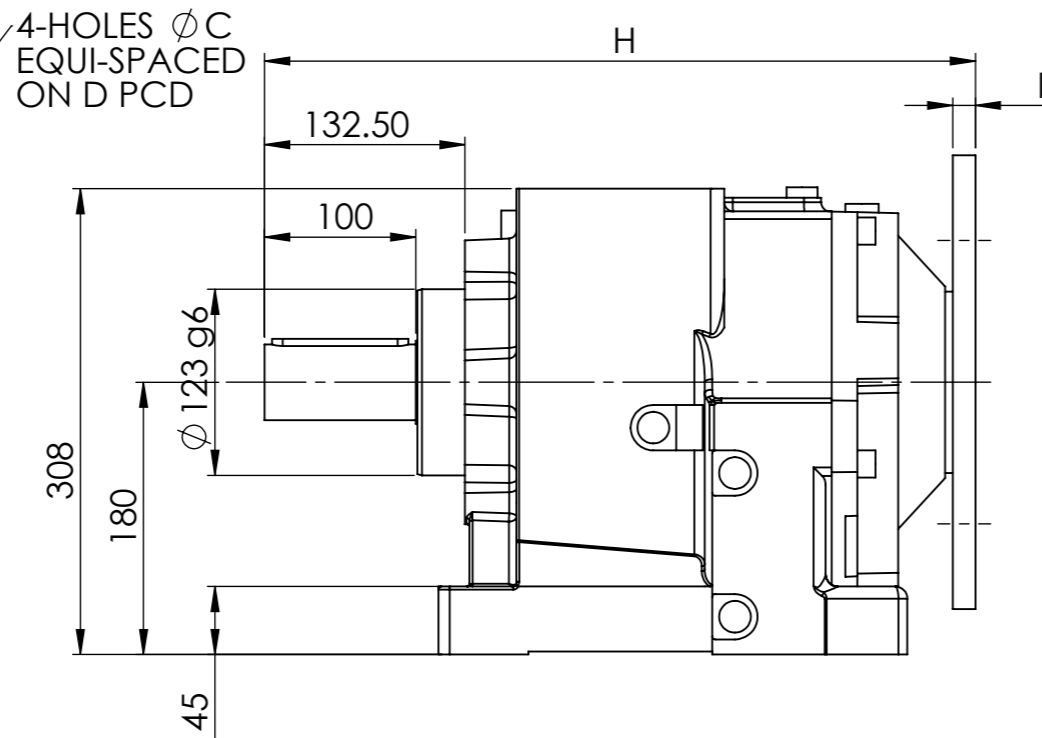
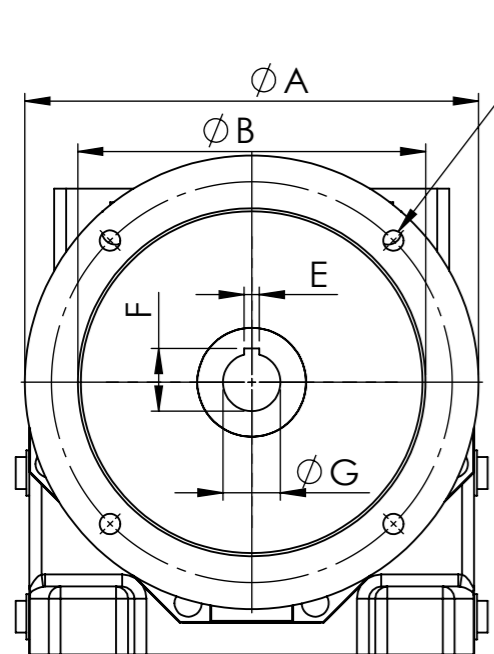

50/3	MOTOR				
RATIO	63	71	80	90	100
60.43		/	/	/	/
70.83		/	/	/	/
83.55	/	/	/	/	/
95.10	/	/	/	/	/
108.97	/	/	/	/	/
125.93	/	/	/	/	/
147.12	/	/	/	/	/
174.36	/	/	/	/	/
197.3	/	/	/	/	/
225.64	/	/	/	/	/
261.54	/	/	/	/	/
308.48	/	/	/	/	/
368.53	/	/	/	/	/
414.10	/	/	/	/	/
464.96	/	/	/	/	/

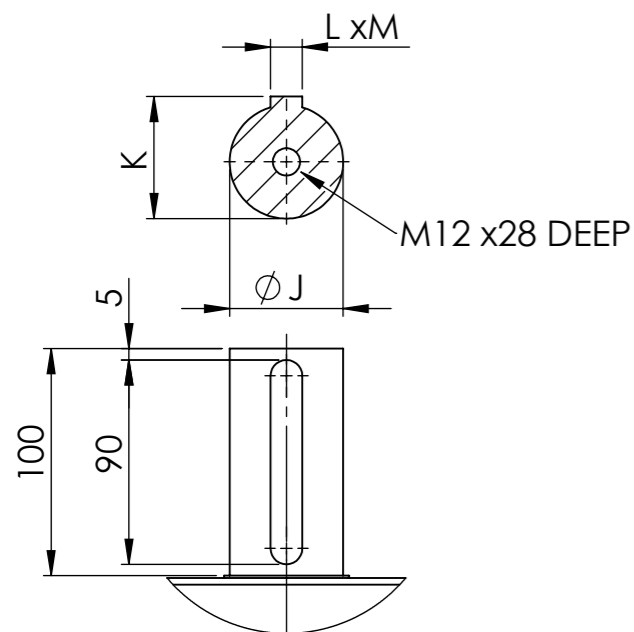

OUTPUT SHAFT DIMENSIONS				
	J(j6)	K	L	M
STANDARD	50	53.5	14	9

EMAG **ELECTRIC MOTORS & GEARBOXES LTD**
 ASHMORE LAKE INDUSTRIAL ESTATE, WILLENHALL, WEST MIDLANDS, WV12 4LH
 PHONE 01902 601403, FAX 01902 601408.
 E MAIL sales @emag-ltd.co.uk

THIS DRAWING IN DESIGN & DETAIL IS THE PROPERTY OF EMAG LTD AND IS INTENDED SOLELY FOR THE USE OF THE PERSON OR COMPANY TO WHOM IT IS ISSUED. IN NO EVENT SHALL IT BE COPIED OR LOANED WITHOUT THE EXPRESS PERMISSION OF EMAG LTD

© ELECTRIC MOTORS & GEARBOXES LTD FIRST ANGLE PROJECTION

TITLE: **MNHL 50** CLIENT:

DRAWN: R SPENCER SCALE: 1:5 (A3) DRG No: **MNHL 50/3 GEAR UNIT**

DATE: