

W cast iron motors

Frame sizes 80 to 355

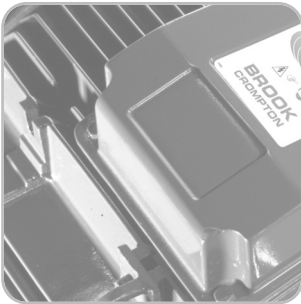

Specification and Introduction



2

Cast Iron Specification

Specification		
	Standard product	Option
Frame sizes	80 - 355	
Enclosure	IP55	IP56, IP65, IP66
Mounting option	Foot (B3), Flange (B5), Face (B14) or Pad (B30)	Foot & Flange (B35), Foot & Face (B34)
Terminal box position	Top, (80 frame right hand side)	Right hand side, left hand side
Voltage	3 kW and below: 230 / 400	-
	4 kW and above: 400 / 690	-
Frequency	50 Hz	60 Hz
Cooling	IC411	IC410, IC416 & IC418
Bearing location	Drive end	Non drive end
Lubrication	80 - 180 double-shielded bearings	Regreasing facility
	200 - 355 regreasing facility	-
Insulation	class F	class H
Temperature rise	class B	class F
Paint colour	water blue (RAL 5021)	on request
Fan cover	Steel	Plastic (80 - 180)
Thermal protection	200 - 355 (by thermistors)	80 - 180
Anti condensation heaters	-	80 - 355
Drain holes	160 - 355	80 - 132
Inverter Duty (with derate)	Variable Torque: 10:1	-
	Constant Torque: 2:1	Alternative speed range
Ambient temperature	-20°C to + 40°C	-50°C to +100°C
AC & DC brake option	-	80 - 355

The above specification and options give a brief summary of features available for the W cast iron range. For a full listing of optional features, please contact Brook Crompton sales.

Brook Crompton

Brook Crompton is a leading supplier of electric motors for the global industrial market, with motor solutions which benefit a wide range of customers.

Our products are used in almost every industrial activity including water treatment, building services, chemical/petrochemicals, general processing and manufacturing where they drive fans, pumps, compressors and conveyors, amongst other things.

Brook Crompton incorporates many well known names including Brook Motors, Crompton Parkinson, Electrodrives, Newman, Bull Electric and Hawker Siddeley Electric Motors.

We have extensive stocks of motors, backed-up by a network of distributors, ensuring excellent local support wherever needed.

Quality assurance

Stringent quality procedures are observed from first design to finished product in accordance with the ISO9001 quality systems.

All of our factories have been assessed to meet these requirements, a further assurance that only the highest standards of quality are accepted.

W cast iron range

The Brook Crompton W motor range covers products with outputs from as little as 0.18kW to 400kW in frame sizes 80 to 355L. They are suitable for use within a diverse range of applications from food and drink to china clay production. From roller table drives to refrigeration. Many applications often have adverse operating conditions including repeated starting and occasional overloading; the 'W' range is well suited to these situations. A virtual 'go anywhere' motor, this cast iron range has a full 3-year guarantee.

Benefits include:

- high efficiency for low running costs
- high reliability for long life
- low noise levels
- cool running for long insulation life
- Eurovoltage: 400V ±10%
- high torque with smooth acceleration and low current
- ease of maintenance
- IP55 protection
- 4-position cable entry
- multi-mount for adaptability
- also available for Zone 2, Zone 21 & 21 see catalogue 2204E for further details

Efficiency

Brook Crompton are an approved manufacturer of ac electric motors within the UK Governments Enhanced Capital Allowance scheme. A wide range of single speed motors are included on the technology list.

Please check the ECA scheme website: www.eca.gov.uk at time of purchase for current listing.

Standards and environment

Standards

Standards			
Motors of cast iron construction can be manufactured to the international standards listed below:			
Range	International	UK	Europe
Standard	IEC	BS, EN & IEC	EN & IEC
Outputs	IEC 60034-1	BS EN 50347:2001	EN 50347
Performance	IEC 60034-1	BS EN 50347:2001 BS EN 60034-30	EN 60034-1
Dimensions	IEC 60072-1	BS EN 50347 BS 4999 part 141	EN 50347
Mounting	IEC 60034-7	BS EN 60034-7	EN 60034-7
Degrees of protection	IEC 60034-5	BS EN 60034-5	EN 60034-5

Motors complying with IEC 60034-1 also comply with many of the national standards of other European countries, eg CEI 203 (Italy), NBN7 (Belgium), NEN 3173 (Netherlands), SEN 2601 01 (Sweden)

Environment Enclosure

All motors have degrees of IP protection as defined in IEC EN 60034-5. The normal arrangement is IP55. See Specification (page 2) for alternatives.

Motor cooling

Motors are cooled in accordance with IEC 60034-6. The normal arrangement is IC411 (Totally Enclosed Fan Ventilated) via a fan mounted at the non-drive end. See Specification (page 2) for alternatives.

European directives

The following European directives apply:

Directives

Compliance with European directives applying to AC induction motors				
Directives	Low voltage (LV)	Machinery (MD)	Electromagnetic compatibility (EMC)	Energy using products (EuP)
Reference numbers	73/23/EEC 93/68/EEC 2006/95/EC	89/392/EEC 93/44/EEC 98/37/EC 98/79/EC 2006/42/EC	89/336/EEC 92/31/EEC 93/68/EEC 2004/108/EC	92/42/EEC 96/57/EC 2000/55/EC 2005/32/EC
Motor CE marked	Yes	No	No	Yes
Standards	EN 60034	Not applicable	EN 60034-1	EN 60034-30
Documentation for customers' technical file	Declaration of conformity	Certificate of incorporation	Statement ⁽¹⁾	Declaration of conformity
Safety instructions with every motor	Yes	Yes	Yes	-
Comment	Relevant electrical equipment operating between 50 to 1000 volts AC	Statement ⁽²⁾	Component	Minimum efficiency levels for motor outputs 0.75 - 375kW 2-6 pole

⁽¹⁾ Motors operating from a correctly applied, sinusoidal (AC) supply meet the requirements of the EMC directive and are within the limits specified in standard EN 60034-1

⁽²⁾ When installed in accordance with our customer safety and installation and maintenance instructions, they can be put into service only when the machinery into which they are being incorporated, has been declared to be in conformity with the machinery directive in accordance with Article 4(2) and Annex IIB of that Directive (98/37/EEC)

Minimum Energy Performance Standard

The new standard

The EU MEPS scheme sets new **mandatory** minimum efficiency levels for most single speed 3ph induction motors up to 375kW rated up to 1000V, unlike the narrow definition of the CEMEP voluntary scheme which only covered a small number of standard motors.

The Voluntary Agreement, since 1998, of CEMEP for motor manufactures has expired (classes EFF3 /EFF2/EFF1).

The new standard for motors is now **mandatory** regulation in Europe.

The scope of EU MEPS covers 2, 4 & 6 pole single speed 3ph induction motors from 0.75 to 375kW, rated up to 1000V based on continuous duty operation.

Aiming to reduce energy consumption throughout Europe and the rest of the world, it comes into effect in 3 stages. The effect of this is to maximise potential savings in electric motor driven systems. Base of the regulation is a new international IEC 60034-30 standard. It defines the following efficiency classes :

- IE1** - Standard Efficiency (comparable to EFF2)
- IE2** - High Efficiency (comparable to EFF1 and USA EPACT 60 Hz)
- IE3** - Premium Efficiency (comparable to USA "NEMA Premium" 60 Hz)

New Efficiency levels in Europe (Time Line)

Mandatory from:

Since 16 June 2011:

Minimum efficiency requirement at IE2 for all motors covered 0.75 - 375kW

From 1 January 2015:

Minimum efficiency requirement at IE3 level for 7.5 - 375kW motors or IE2 level for motors equipped with an appropriate variable speed drive.

From 1 January 2017:

Minimum efficiency requirement at IE3 level for 0.75 - 375kW motors or IE2 level for motors equipped with an appropriate variable speed drive.

Performance data



4 3000 min⁻¹ (2 pole)

Rated power Full load speed in revolutions per minute Frame reference and size Full load current at rated voltage Efficiency Power factor Full load torque Direct on line starting torque ratio Direct on line starting current ratio Direct on line pull up torque ratio Direct on line pull up torque Star delta starting torque ratio (I) Star delta starting current ratio Rotor inertia Wkg Mean sound pressure level @ 1m on no load

P _N kW (hp)	n min ⁻¹	Type	IE3	I _N			η		Cos φ		M _N Nm	M _A M _N	I _A I _N	M _K M _N	M _S M _N	M _A M _N Y	I _A I _N Y	M _S M _N Y	J kgm ²	L _{PA} dB(A)
				230 V A	400 V A	690 V A	1.0 P _N 0.75 P _N	0.75 P _N 0.5 P _N	1.0 P _N 0.75 P _N	0.75 P _N 0.5 P _N										
0.75 (1.0)	2890	WP-DF80MM ⁽¹⁾	IE3	2.7	1.55	-	80.7 81.0 77.0	0.86 0.80 0.68			2.5	3.3	7.7	3.1	2.5	-	-	-	0.0013	64
1.1 (1.5)	2885	WP-DF80MS ⁽¹⁾	IE3	3.95	2.30	-	83.5 84.8 83.5	0.84 0.78 0.66			3.6	3.5	7.7	3.1	2.8	-	-	-	0.0012	64
1.5 (2.0)	2880	WP-DF90LMX ⁽¹⁾	IE3	5.25	3.00	-	84.2 84.5 82.0	0.86 0.81 0.70			5.0	3.4	8.2	3.6	2.8	-	-	-	0.0014	64
2.2 (3.0)	2895	WP-DF90LSX ⁽¹⁾	IE3	7.9	4.6	-	85.9 85.9 84.2	0.81 0.73 0.59			7.3	3.8	8.5	4.1	3.6	-	-	-	0.0016	64
3.0 (4.0)	2880	WP-DF100LMF ⁽¹⁾	IE3	9.7	5.6	-	87.1 88.7 88.7	0.93 0.90 0.84			10	3.0	8.2	3.3	2.8	-	-	-	0.0058	60
4.0 (5.5)	2895	WP-DF112MR ⁽¹⁾	IE3	-	7.3	4.2	88.5 89.2 88.5	0.90 0.85 0.74			13.2	3.9	10	4.8	3.8	1.2	3.1	1.2	0.0064	60
5.5 (7.5)	2930	WP-DF132SGX ⁽¹⁾	IE3	-	10.6	6.1	90.5 90.5 88.8	0.83 0.76 0.63			17.9	3.9	10	4.8	3.6	1.2	3.1	1.1	0.015	66
7.5 (10)	2930	WP-DF132SMX ⁽¹⁾	IE3	-	13.7	7.9	91.0 91.2 90.3	0.87 0.81 0.70			24.5	3.6	9.6	4.3	3.3	1.1	3.0	1.0	0.018	66
11 (15)	2945	WP-DF160MJ ⁽¹⁾	IE3	-	19.6	11.3	92.2 92.5 91.5	0.88 0.85 0.77			35.7	3.6	7.6	3.6	1.8	1.1	2.4	0.6	0.045	68
15 (20)	2940	WP-DF160MR ⁽¹⁾	IE3	-	26.0	15.0	93.0 93.3 93.1	0.90 0.87 0.79			48.7	2.2	8.6	3.7	1.9	0.7	2.7	0.6	0.056	68
18.5 (25)	2955	WP-DF160LT ⁽¹⁾	IE3	-	32.5	18.8	93.3 93.4 92.5	0.88 0.84 0.75			59.8	2.7	9.0	4.0	2.2	0.84	2.8	0.7	0.063	68
22 (30)	2950	WP-DF180MF ⁽¹⁾	IE3	-	38.1	22.1	93.6 93.6 93.1	0.89 0.85 0.77			71.3	2.4	9.5	4.0	2.1	0.75	3.0	0.66	0.089	68
30 (40)	2950	WP-UDF200LNX ⁽²⁾ WP-DF200LNX ⁽³⁾	IE3	-	53.0	30.5	93.3 93.3 93.0	0.88 0.85 0.78			97.2	2.8	9.0	3.0	2.4	0.88	2.8	0.75	0.15	73
37 (50)	2945	WP-UDF200LNX ⁽²⁾ WP-DF200LNX ⁽³⁾	IE3	-	65.0	37.5	93.7 93.7 93.3	0.88 0.85 0.78			120	2.7	7.8	2.9	2.3	0.75	2.5	0.60	0.18	73
45 (60)	2960	WP-UDF225MP ⁽²⁾ WP-DF225MP ⁽³⁾	IE3	-	77.0	44.5	94.3 94.3 93.3	0.90 0.88 0.83			145	2.3	7.8	2.8	1.9	0.65	2.5	0.50	0.38	75
55 (75)	2955	WP-UDF250MNE ⁽²⁾ WP-DF250SN ⁽³⁾	IE3	-	92	53	94.6 94.6 94.5	0.92 0.91 0.86			178	2.2	7.8	2.8	1.9	0.7	2.5	0.50	0.56	75

⁽¹⁾ European and BS frame reference

⁽²⁾ European frame reference

⁽³⁾ BS frame reference

Performance data



5

3000 min⁻¹ (2 pole)

Rated power P_N kW (hp)	Full load speed in revolutions per minute n min ⁻¹	Frame reference and size Type	Full load current at rated voltage I_N			Efficiency η		Power factor $\cos \phi$	Full load torque M_N Nm	Direct on line starting torque ratio $\frac{M_A}{M_N}$	Direct on line starting current ratio $\frac{I_A}{I_N}$	Direct on line pull out torque ratio $\frac{M_K}{M_N}$	Direct on line pull up torque ratio $\frac{M_S}{M_N}$	Star delta starting torque ratio ⁽¹⁾ $\frac{M_A}{M_N}$ Y	Star delta starting current ratio $\frac{I_A}{I_N}$ Y	Star delta pull up torque ratio $\frac{M_S}{M_N}$ Y	Rotor inertia I_{rK} J kgm ²	Mean sound pressure level @ 1m on no load L_{PA} dB(A)
			230 V A	400 V A	690 V A	1.0 P_N 0.75 P_N 0.5 P_N	1.0 P_N 0.75 P_N 0.5 P_N											
0.75 (1.0)	2880	WU-DF80MJ ⁽¹⁾	IE2	2.85	1.65	-	$\left\{ \begin{array}{l} 77.4 \\ 76.9 \\ 75.2 \end{array} \right\}$	$\left\{ \begin{array}{l} 0.84 \\ 0.78 \\ 0.66 \end{array} \right\}$	2.5	3.0	7.1	2.7	2.4	-	-	-	0.0010	64
1.1 (1.5)	2880	WU-DF80MM ⁽¹⁾	IE2	4.20	2.35	-	$\left\{ \begin{array}{l} 79.6 \\ 80.7 \\ 78.6 \end{array} \right\}$	$\left\{ \begin{array}{l} 0.84 \\ 0.77 \\ 0.65 \end{array} \right\}$	3.6	2.8	6.7	2.7	2.4	-	-	-	0.0012	64
1.5 (2.0)	2850	WU-DF90LMX ⁽¹⁾	IE2	5.15	2.97	-	$\left\{ \begin{array}{l} 81.3 \\ 82.3 \\ 82.6 \end{array} \right\}$	$\left\{ \begin{array}{l} 0.90 \\ 0.84 \\ 0.76 \end{array} \right\}$	5.0	2.8	7.1	3.1	2.4	-	-	-	0.0014	64
2.2 (3.0)	2890	WU-DF90LSX ⁽¹⁾	IE2	8.0	4.6	-	$\left\{ \begin{array}{l} 83.2 \\ 85.4 \\ 84.1 \end{array} \right\}$	$\left\{ \begin{array}{l} 0.82 \\ 0.72 \\ 0.58 \end{array} \right\}$	7.3	2.5	7.3	3.0	2.5	-	-	-	0.0016	64
3.0 (4.0)	2890	WU-DF100LR ⁽¹⁾	IE2	10.2	5.9	-	$\left\{ \begin{array}{l} 84.6 \\ 82.7 \\ 75.2 \end{array} \right\}$	$\left\{ \begin{array}{l} 0.88 \\ 0.74 \\ 0.54 \end{array} \right\}$	9.9	3.1	8.1	3.1	2.4	-	-	-	0.0050	60
4.0 (5.5)	2870	WU-DF112MM ⁽¹⁾	IE2	-	7.3	4.2	$\left\{ \begin{array}{l} 85.8 \\ 89.2 \\ 87.4 \end{array} \right\}$	$\left\{ \begin{array}{l} 0.91 \\ 0.88 \\ 0.81 \end{array} \right\}$	13.3	3.0	7.8	3.1	2.8	0.93	2.4	0.87	0.0055	60
5.5 (7.5)	2910	WU-DF132SE ⁽¹⁾	IE2	-	10.2	5.9	$\left\{ \begin{array}{l} 87.0 \\ 88.8 \\ 87.9 \end{array} \right\}$	$\left\{ \begin{array}{l} 0.89 \\ 0.83 \\ 0.70 \end{array} \right\}$	18.0	2.7	8.2	3.1	2.4	0.84	2.6	0.75	0.012	66
7.5 (10)	2900	WU-DF132SJ ⁽¹⁾	IE2	-	13.5	7.8	$\left\{ \begin{array}{l} 88.1 \\ 88.4 \\ 88.5 \end{array} \right\}$	$\left\{ \begin{array}{l} 0.91 \\ 0.88 \\ 0.82 \end{array} \right\}$	24.7	2.5	8.2	3.0	2.3	0.78	2.6	0.72	0.015	66
11 (15)	2940	WU-DF160MB ⁽¹⁾	IE2	-	20.0	11.5	$\left\{ \begin{array}{l} 89.4 \\ 89.7 \\ 88.5 \end{array} \right\}$	$\left\{ \begin{array}{l} 0.89 \\ 0.84 \\ 0.76 \end{array} \right\}$	35.7	2.2	7.8	3.0	1.8	0.68	2.4	0.56	0.039	68
15 (20)	2940	WU-DF160MJ ⁽¹⁾	IE2	-	26.6	15.4	$\left\{ \begin{array}{l} 90.3 \\ 89.8 \\ 88.8 \end{array} \right\}$	$\left\{ \begin{array}{l} 0.80 \\ 0.86 \\ 0.79 \end{array} \right\}$	48.7	2.2	8.0	3.1	1.9	0.68	2.5	0.60	0.045	68
18.5 (25)	2930	WU-DF160LR ⁽¹⁾	IE2	-	32.5	18.8	$\left\{ \begin{array}{l} 90.9 \\ 90.6 \\ 89.8 \end{array} \right\}$	$\left\{ \begin{array}{l} 0.90 \\ 0.86 \\ 0.80 \end{array} \right\}$	60.3	2.4	8.7	3.2	1.9	0.75	2.7	0.60	0.056	68
22 (30)	2950	WU-DF180ME ⁽¹⁾	IE2	-	39.0	22.5	$\left\{ \begin{array}{l} 91.3 \\ 91.5 \\ 90.4 \end{array} \right\}$	$\left\{ \begin{array}{l} 0.89 \\ 0.86 \\ 0.76 \end{array} \right\}$	71.2	2.2	9.0	3.1	1.9	0.68	2.8	0.60	0.084	68
30 (40)	2945	WU-DF200LGX ⁽²⁾ W-DF200LGX ⁽³⁾	IE2	-	53	31	$\left\{ \begin{array}{l} 92.0 \\ 90.0 \\ 88.4 \end{array} \right\}$	$\left\{ \begin{array}{l} 0.89 \\ 0.86 \\ 0.79 \end{array} \right\}$	97.3	2.7	7.8	2.9	2.3	0.75	2.5	0.60	0.15	73
37 (50)	2945	WU-DF200LNX ⁽²⁾ W-DF200LNX ⁽³⁾	IE2	-	66	38	$\left\{ \begin{array}{l} 92.5 \\ 93.1 \\ 92.6 \end{array} \right\}$	$\left\{ \begin{array}{l} 0.88 \\ 0.80 \\ 0.76 \end{array} \right\}$	120	2.7	7.8	2.9	2.3	0.75	2.5	0.60	0.18	73
45 (60)	2955	WU-DF225MN ⁽²⁾ W-DF225MN ⁽³⁾	IE2	-	78	45	$\left\{ \begin{array}{l} 92.9 \\ 93.3 \\ 92.6 \end{array} \right\}$	$\left\{ \begin{array}{l} 0.90 \\ 0.89 \\ 0.84 \end{array} \right\}$	145	2.3	7.8	2.8	1.9	0.65	2.5	0.50	0.47	75
55 (75)	2955	WU-DF250MNE ⁽²⁾ W-DF250SN ⁽³⁾	IE2	-	94	54	$\left\{ \begin{array}{l} 93.2 \\ 94.6 \\ 93.7 \end{array} \right\}$	$\left\{ \begin{array}{l} 0.91 \\ 0.90 \\ 0.86 \end{array} \right\}$	178	2.3	7.8	2.8	1.9	0.65	2.5	0.50	0.56	75

⁽¹⁾ European and BS frame reference

⁽²⁾ European frame reference

⁽³⁾ BS frame reference

Performance data



6 3000 min⁻¹ (2 pole)

P _N kW (hp)	n min ⁻¹	Type	IE3	I _N		η		Cos φ		M _N Nm	M _A M _N	I _A I _N	M _K M _N	M _S M _N	M _A M _N Y	I _A I _N Y	M _S M _N Y	J kgm ²	L _{PA} dB(A)
				400 V A	690 V A	1.0 P _N 0.75 P _N 0.5 P _N	1.0 P _N 0.75 P _N 0.5 P _N	1.0 P _N 0.75 P _N 0.5 P _N	1.0 P _N 0.75 P _N 0.5 P _N										
75 (100)	2960	WP-UDF280SNE ⁽²⁾ WP-DF250MN ⁽³⁾	IE3	127	73	95.0 95.1 95.0	0.87 0.90 0.83	242	2.2	7.8	3.0	2.0	0.65	2.5	0.50	0.7	77		
90 (125)	2960	WP-UDF280MNE ⁽²⁾ WP-DF280SN ⁽³⁾	IE3	150	87	95.3 95.5 95.3	0.82 0.88 0.82	291	2.2	7.8	3.0	2.0	0.65	2.5	0.50	0.8	77		
110 (150)	2980	WP-UDF315SNE ⁽²⁾ WP-DF280MN ⁽³⁾	IE3	183	106	95.2 95.2 95.2	0.89 0.91 0.84	353	2.2	7.8	2.9	1.8	0.65	2.5	0.45	1.4	78		
132 (175)	2975	WP-UDF315MNE ⁽²⁾ WP-DF315SN ⁽³⁾	IE3	222	129	94.8 95.4 95.5	0.85 0.90 0.89	424	2.2	7.8	2.9	1.8	0.65	2.5	0.45	1.7	78		
150 (200)	2980	WP-UDF315MN ⁽²⁾ WP-DF315MN ⁽³⁾	IE3	249	144	94.1 95.3 95.5	0.84 0.89 0.91	481	2.0	7.8	2.8	1.7	0.60	2.5	0.45	2.4	80		
160 (215)	2980	WP-UDF315MP ⁽²⁾ WP-DF315MP ⁽³⁾	IE3	265	154	94.5 95.5 95.5	0.83 0.89 0.91	513	2.0	7.8	2.8	1.7	0.60	2.5	0.45	2.6	80		
185 (250)	2975	WP-UDF315LN ⁽²⁾ WP-DF315LN ⁽³⁾	IE3	304	176	95.0 95.7 95.0	0.85 0.89 0.92	594	2.0	7.8	2.8	1.7	0.60	2.5	0.45	2.8	80		
200 (270)	2980	WP-UDF315LP ⁽²⁾ WP-DF315LP ⁽³⁾	IE3	328	190	95.3 95.8 95.8	0.86 0.90 0.86	641	2.1	7.9	2.9	1.6	0.66	2.5	0.9	2.23	80		
225 (300)	2985	WP-UDF355SG ⁽²⁾ WP-DF355SG ⁽³⁾	IE3	381	221	95.4 95.8 95.4	0.86 0.89 0.82	720	2.0	7.5	2.7	1.6	0.63	2.4	0.9	5.0	80		
250 (335)	2980	WP-UDF355SJ ⁽²⁾ WP-DF355SJ ⁽³⁾	IE3	419	243	93.8 95.2 95.8	0.81 0.86 0.89	802	2.0	7.5	2.7	1.6	0.63	2.4	0.9	5.3	80		
280 (375)	2980	WP-UDF355SN ⁽¹⁾ WP-DF355SN ⁽³⁾	IE3	474	275	94.2 95.3 95.8	0.84 0.88 0.89	898	2.0	7.5	2.7	1.6	0.63	2.4	0.9	5.9	80		
315 (420)	2985	WP-UDF355MJ ⁽²⁾ WP-DF355MJ ⁽³⁾	IE3	533	309	95.0 95.8 95.8	0.85 0.88 0.89	1008	2.0	7.5	2.7	1.6	0.65	2.3	0.45	6.3	80		
355 (475)	2985	WP-UDF355MN ⁽²⁾ WP-DF355MN ⁽³⁾	IE3	600	348	95.0 95.8 95.8	0.85 0.88 0.89	1136	2.0	7.5	2.7	1.6	0.65	2.3	0.45	7.0	80		
375 (503)	2985	WP-UDF355LN ⁽²⁾ WP-DF355LN ⁽³⁾	IE3	621	360	95.3 95.8 95.8	0.85 0.90 0.91	1120	2.6	7.3	3.2	2.0	0.8	2.28	0.63	8.0	80		

⁽¹⁾ European and BS frame reference

⁽²⁾ European frame reference

⁽³⁾ BS frame reference

Performance data



3000 min⁻¹ (2 pole)

P _N kW (hp)	n min ⁻¹	Type	IE2	I _N		η		Cos φ		M _N Nm	M _A M _N	I _A I _N	M _K M _N	M _S M _N	M _A M _N Y	I _A I _N Y	M _S M _N Y	J kgm ²	L _{PA} dB(A)
				400 V A	690 V A	1.0 P _N 0.75 P _N	0.75 P _N 0.5 P _N	1.0 P _N 0.75 P _N	0.75 P _N 0.5 P _N										
75 (100)	2960	WU-DF280SNE ⁽²⁾ W-DF250MN ⁽³⁾	IE2	128	74	93.8 95.1 94.3	0.90 0.91 0.90			242	2.2	7.8	3.0	2.0	0.65	2.5	0.50	0.7	77
90 (125)	2960	WU-DF280MNE ⁽²⁾ W-DF280SN ⁽³⁾	IE2	152	88	94.1 95.2 94.7	0.91 0.89 0.83			290	2.2	7.8	3.0	2.0	0.65	2.5	0.50	0.8	77
110 (150)	2980	WU-DF315SNE ⁽²⁾ W-DF280MN ⁽³⁾	IE2	185	107	94.3 94.8 93.7	0.91 0.90 0.85			353	2.2	7.8	2.9	1.8	0.65	2.5	0.45	1.4	78
132 (175)	2975	WU-DF315MNE ⁽²⁾ W-DF315SN ⁽³⁾	IE2	224	130	94.6 96.3 95.9	0.90 0.91 0.88			423	2.2	7.8	2.9	1.8	0.65	2.5	0.45	1.7	78
150 (200)	2980	WU-DF315MN ⁽²⁾ W-DF315MN ⁽³⁾	IE2	251	146	94.7 95.4 94.5	0.91 0.88 0.83			481	2.0	7.8	2.8	1.7	0.60	2.5	0.45	2.4	80
160 (215)	2980	WU-DF315MP ⁽²⁾ W-DF315MP ⁽³⁾	IE2	268	155	94.8 96.0 95.1	0.91 0.88 0.83			513	2.0	7.8	2.8	1.7	0.60	2.5	0.45	2.6	80
185 (250)	2980	WU-DF315LN ⁽²⁾ W-DF315LN ⁽³⁾	IE2	309	179	95.0 95.5 94.6	0.91 0.90 0.86			593	2.0	7.8	2.8	1.7	0.60	2.5	0.45	2.8	80
200 (270)	2980	WU-DF315LN ⁽²⁾ W-DF315LN ⁽³⁾	IE2	334	191	95.0 96.0 95.0	0.91 0.91 0.87			641	1.9	7.1	2.5	1.6	0.55	2.3	0.42	2.8	80
225 (300)	2985	WU-DF355SG ⁽²⁾ W-DF355SG ⁽³⁾	IE2	384	227	95.0 95.5 94.4	0.89 0.86 0.81			720	2.0	7.5	2.7	1.6	0.65	2.3	0.45	5.0	80
250 (335)	2980	WU-DF355SJ ⁽²⁾ W-DF355SJ ⁽³⁾	IE2	427	247	95.0 95.6 94.6	0.89 0.87 0.81			801	2.0	7.5	2.7	1.6	0.65	2.3	0.45	5.3	80
280 (375)	2980	WU-DF355SN ⁽¹⁾ W-DF355SN ⁽³⁾	IE2	478	276	95.0 95.8 94.8	0.89 0.87 0.82			897	2.0	7.5	2.7	1.6	0.65	2.3	0.45	5.9	80
315 (420)	2980	WU-DF355MJ ⁽²⁾ W-DF355MJ ⁽³⁾	IE2	532	307	95.0 96.2 95.4	0.90 0.93 0.84			1009	2.0	7.5	2.7	1.6	0.65	2.3	0.45	6.3	80
355 (475)	2980	WU-DF355MN ⁽²⁾ W-DF355MN ⁽³⁾	IE2	599	346	95.0 96.0 95.5	0.90 0.88 0.83			1137	2.0	7.5	2.7	1.6	0.65	2.3	0.45	7.0	80
375 (503)	2980	WU-DF355LN ⁽²⁾ W-DF355LN ⁽³⁾	IE2	660	381	95.7 95.4 95.1	0.91 0.90 0.86			1282	2.0	7.5	2.7	1.6	0.65	2.3	0.45	8.0	80

⁽¹⁾ European and BS frame reference

⁽²⁾ European frame reference

⁽³⁾ BS frame reference

Performance data



8

1500 min⁻¹ (4 pole)

P _N kW (hp)	n min ⁻¹	Type	IE3	I _N			η		Cos φ	M _N Nm	M _A M _N	I _A I _N	M _K M _N	M _S M _N	M _A M _N Y	I _A I _N Y	M _S M _N Y	J kgm ²	L _{PA} dB(A)
				230 V A	400 V A	690V A	1.0 P _N 0.75 P _N	1.0 P _N 0.75 P _N 0.5 P _N											
0.75 (1.0)	-	tbc	IE3	-	-	-	{ - - -}	{ - - -}	-	-	-	-	-	-	-	-	-	-	-
1.1 (1.5)	1430	WP-DF90LTX ⁽¹⁾	IE3	4.2	2.5	-	{ 84.1 84.4 84.0	{ 0.77 0.70 0.57	7.3	3.0	7.0	3.5	2.7	-	-	-	0.0037	48	
1.5 (2.0)	1440	WP-DF90LWX ⁽¹⁾	IE3	6.3	3.6	-	{ 85.3 85.3 83.2	{ 0.70 0.58 0.46	10.0	4.2	7.4	4.7	4.1	-	-	-	0.0042	48	
2.2 (3.0)	1450	WP-DF100LRF ⁽¹⁾	IE3	8.1	4.6	-	{ 86.7 87.0 86.0	{ 0.79 0.70 0.57	14.5	3.3	7.3	3.3	3.0	-	-	-	0.0107	54	
3.0 (4.0)	1460	WP-DF100LTF ⁽¹⁾	IE3	11.6	6.7	-	{ 87.7 87.7 85.8	{ 0.74 0.63 0.50	19.6	3.7	8.1	4.0	3.2	-	-	-	0.0118	54	
4.0 (5.5)	1450	WP-DF112MWX ⁽¹⁾	IE3	-	8.4	4.8	{ 88.6 88.0	{ 0.78 0.70 0.56	26.4	3.5	8.0	3.5	2.9	1.1	2.5	0.9	0.0151	54	
5.5 (7.5)	1460	WP-DF132STX ⁽¹⁾	IE3	-	10.9	6.3	{ 89.6 90.0 88.7	{ 0.81 0.73 0.60	36.0	3.3	8.7	3.9	2.7	1.0	2.7	0.84	0.03	59	
7.5 (10)	1450	WP-DF132MVX ⁽¹⁾	IE3	-	14.6	8.5	{ 90.4 91.3 90.4	{ 0.82 0.73 0.60	49.4	3.2	7.6	3.4	2.6	1.0	2.4	0.8	0.033	59	
11 (15)	1475	WP-DF160MR ⁽¹⁾	IE3	-	20.9	12.1	{ 92.5 92.8 92.0	{ 0.82 0.75 0.62	71.3	3.0	9.0	3.7	2.4	0.94	2.8	0.75	0.084	63	
15 (20)	1475	WP-DF160LU ⁽¹⁾	IE3	-	28.1	16.3	{ 92.8 93.0 92.3	{ 0.83 0.76 0.62	97.2	3.2	9.1	3.5	2.4	1.0	2.84	0.75	0.098	63	
18.5 (25)	1475	WP-DF180ME ⁽¹⁾	IE3	-	34.7	20.1	{ 92.6 92.8 92.0	{ 0.83 0.74 0.60	120	2.8	8.4	3.0	2.0	0.88	2.6	0.63	0.16	62	
22 (30)	1470	WP-DF180LM ⁽¹⁾	IE3	-	41.1	23.8	{ 93.0 93.0 93.0	{ 0.83 0.75 0.62	143	3.1	8.8	3.0	2.0	0.95	2.75	0.63	0.17	62	
30 (40)	1470	WP-UDF200LN ⁽²⁾ WP-DF200LN ⁽³⁾	IE3	-	54.0	31.0	{ 93.6 93.6 93.0	{ 0.86 0.83 0.75	195	2.3	7.5	3.2	1.9	0.7	2.4	0.55	0.31	65	
37 (50)	1475	WP-UDF225SR ⁽²⁾ WP-DF225SR ⁽³⁾	IE3	-	64.5	37.5	{ 93.9 93.9 93.0	{ 0.88 0.82 0.74	240	2.7	8.4	2.9	2.1	0.84	2.6	0.66	0.42	66	
45 (60)	1480	WP-UDF225MN ⁽²⁾ WP-DF225MN ⁽³⁾	IE3	-	80.0	46	{ 94.2 94.3 93.5	{ 0.86 0.84 0.75	291	2.7	7.7	3.2	1.9	0.75	2.5	0.55	0.50	67	
55 (75)	1480	WP-UDF250MPE ⁽²⁾ WP-DF250SP ⁽³⁾	IE3	-	95.5	56	{ 94.6 94.8 94.2	{ 0.88 0.84 0.76	355	2.7	8.3	2.9	2.2	0.84	2.6	0.7	0.66	67	

⁽¹⁾ European and BS frame reference

⁽²⁾ European frame reference

⁽³⁾ BS frame reference

Performance data



9

1500 min⁻¹ (4 pole)

P _N kW (hp)	n min ⁻¹	Type	I _N			η		Cos φ	M _N Nm	M _A M _N	I _A I _N	M _K M _N	M _S M _N	M _A M _N Y	I _A I _N Y	M _S M _N Y	J kgm ²	L _{PA} dB(A)
			230 V A	400 V A	690V A	1.0 P _N 0.75 P _N	1.0 P _N 0.75 P _N 0.5 P _N											
0.55 (0.75)	1410	WU-DF80ME ⁽¹⁾	-	1.69	-	77.0 77.0 73.0	0.84 0.77 0.65	2.5	2.2	5.5	2.5	2.0	-	-	-	0.0014	47	
0.75 (1.0)	1440	WU-DF80MS ⁽¹⁾	IE2	3.3	1.9	-	79.6 78.8 77.4	0.72 0.62 0.49	5.0	3.8	6.8	3.8	1.8	-	-	-	0.0019	47
1.1 (1.5)	1425	WU-DF90LRX ⁽¹⁾	IE2	4.4	2.5	-	81.4 81.5 82.0	0.77 0.78 0.58	7.4	2.3	5.2	2.9	2.3	-	-	-	0.0034	48
1.5 (2.0)	1440	WU-DF90LWX ⁽¹⁾	IE2	6.5	3.7	-	82.8 83.0 81.0	0.70 0.58 0.46	9.9	4.2	7.4	4.7	3.6	-	-	-	0.0042	48
2.2 (3.0)	1435	WU-DF100LS ⁽¹⁾	IE2	8.9	5.1	-	84.3 83.6 81.4	0.74 0.66 0.53	14.6	3.1	6.6	3.1	2.6	-	-	-	0.0103	54
3.0 (4.0)	1455	WU-DF100LTF ⁽¹⁾	IE2	11.9	6.8	-	85.5 83.5 82.6	0.74 0.63 0.50	19.7	3.9	8.5	4.0	2.8	-	-	-	0.0118	54
4.0 (5.5)	1440	WU-DF112MT ⁽¹⁾	IE2	-	8.7	5.0	86.6 86.6 85.9	0.77 0.69 0.55	26.5	3.0	7.4	3.1	2.6	-	-	-	0.012	56
5.5 (7.5)	1455	WU-DF132STX ⁽¹⁾	IE2	-	11.1	6.4	87.7 88.0 87.2	0.82 0.74 0.63	36.1	2.4	7.1	3.0	2.3	-	-	-	0.03	59
7.5 (10)	1460	WU-DF132MVX ⁽¹⁾	IE2	-	14.7	8.5	88.7 89.4 88.6	0.83 0.76 0.67	49.1	2.9	8.1	3.2	2.5	-	-	-	0.033	59
11 (15)	1465	WU-DF160MJ ⁽¹⁾	IE2	-	21.0	12.1	89.8 91.0 90.4	0.83 0.78 0.67	71.7	2.5	7.7	2.9	2.0	0.65	2.3	0.50	0.068	63
15 (20)	1460	WU-DF160LR ⁽¹⁾	IE2	-	28.0	16.2	90.6 91.8 91.6	0.85 0.81 0.71	98.1	2.5	7.7	2.9	2.0	0.65	2.3	0.50	0.084	63
18.5 (25)	1470	WU-DF180ME ⁽¹⁾	IE2	-	35.0	20.2	91.2 91.8 90.7	0.84 0.77 0.66	120	2.8	8.4	3.2	2.2	0.80	2.6	0.65	0.16	62
22 (30)	1470	WU-DF180LJ ⁽¹⁾	IE2	-	41.0	23.7	91.6 92.1 91.6	0.86 0.83 0.71	143	2.6	7.6	2.9	2.0	0.75	2.2	0.60	0.19	62
30 (40)	1470	WU-DF200LN ⁽²⁾ W-DF200LN ⁽³⁾	IE2	-	55	32	92.3 93.1 92.6	0.86 0.83 0.74	195	2.3	7.5	3.2	1.9	0.7	2.4	0.55	0.31	65
37 (50)	1475	WU-DF225SN ⁽²⁾ W-DF225SN ⁽³⁾	IE2	-	66	38	92.7 93.2 92.5	0.87 0.83 0.74	240	2.3	7.3	3.2	1.9	0.7	2.3	0.55	0.45	66
45 (60)	1480	WU-DF225MN ⁽²⁾ W-DF225MN ⁽³⁾	IE2	-	81	47	93.1 93.1 93.1	0.86 0.86 0.79	291	2.7	7.7	3.2	1.9	0.75	2.5	0.55	0.65	67
55 (75)	1475	WU-DF250MNE ⁽²⁾ W-DF250SN ⁽³⁾	IE2	-	98	57	93.5 92.8 92.2	0.87 0.81 0.76	356	2.7	7.7	3.2	1.9	0.75	2.5	0.55	0.75	67

⁽¹⁾ European and BS frame reference

⁽²⁾ European frame reference

⁽³⁾ BS frame reference



Performance data

10

1500 min⁻¹ (4 pole)

P _N kW (hp)	n min ⁻¹	Type	Frame reference and size	Full load current at rated voltage		Efficiency		Power factor	Full load torque M _N Nm	Direct on line starting torque ratio M _A /M _N	Direct on line starting current ratio I _A /I _N	Direct on line pull up torque ratio M _K /M _N	Direct on line pull up torque ratio M _S /M _N	Star delta starting torque ratio ⁽¹⁾ I _A /I _N Y	Star delta starting current ratio M _S /M _N Y	J kgm ²	L _{PA} dB(A)
				400 V A	690 V A	1.0 P _N 0.75 P _N 0.5 P _N	1.0 P _N 0.75 P _N 0.5 P _N										
75 (100)	1480	WP-UDF280SNE ⁽²⁾ WP-DF250MN ⁽³⁾	IE3	134	78	{ 95.0 95.1 95.0 }	{ 0.83 0.85 0.76 }	484	2.4	7.4	2.7	1.9	0.72	2.3	0.54	0.66	69
90 (125)	1480	WP-UF280MNE ⁽²⁾ WP-DF280SN ⁽³⁾	IE3	158	92	{ 95.0 95.2 95.0 }	{ 0.82 0.86 0.76 }	581	2.5	7.4	2.8	2.0	0.75	2.4	0.55	1.6	69
110 (150)	1485	WP-UDF315SNE ⁽²⁾ WP-DF280MN ⁽³⁾	IE3	191	111	{ 95.3 95.8 95.3 }	{ 0.77 0.87 0.85 }	708	2.4	7.7	2.6	2.0	0.70	2.5	0.5	3.2	71
132 (175)	1485	WP-UF315MNE ⁽²⁾ WP-DF315SN ⁽³⁾	IE3	229	133	{ 95.5 95.6 95.5 }	{ 0.77 0.87 0.85 }	849	2.4	7.7	2.6	2.0	0.70	2.5	0.5	3.7	71
150 (200)	1490	WP-UDF315MN ⁽²⁾ WP-DF315MN ⁽³⁾	IE3	254	147	{ 95.5 96.0 96.1 }	{ 0.77 0.89 0.85 }	962	2.4	7.8	2.7	2.0	0.70	2.5	0.5	4.4	73
160 (215)	1490	WP-UDF315MP ⁽²⁾ WP-DF315MP ⁽³⁾	IE3	268	155	{ 95.9 96.0 96.0 }	{ 0.80 0.90 0.88 }	1026	2.4	7.8	2.7	2.0	0.70	2.5	0.5	4.7	73
185 (250)	1490	WP-UDF315LN ⁽²⁾ WP-DF315LN ⁽³⁾	IE3	309	179	{ 95.9 96.0 96.0 }	{ 0.79 0.90 0.86 }	1186	2.4	7.8	2.7	2.2	0.70	2.5	0.5	5.5	73
200 (270)	1490	WP-UDF315LN ⁽²⁾ WP-DF315LN ⁽³⁾	IE3	334	194	{ 95.9 96.0 96.0 }	{ 0.79 0.90 0.86 }	1282	2.3	7.6	2.6	1.9	0.65	2.4	0.45	5.5	73
225 (300)	1490	WP-UDF355SG ⁽²⁾ WP-DF355SG ⁽³⁾	IE3	383	222	{ 96.0 96.4 96.0 }	{ 0.80 0.88 0.86 }	1443	2.0	6.6	2.3	1.6	0.62	2.2	0.5	8.2	76
250 (335)	1485	WP-UDF355SJ ⁽²⁾ WP-DF355SJ ⁽³⁾	IE3	427	248	{ 95.4 96.0 96.0 }	{ 0.80 0.88 0.86 }	1608	2.0	5.7	2.5	1.6	0.62	1.8	0.5	9.5	76
280 (375)	1490	WP-UDF355SN ⁽²⁾ WP-DF355SN ⁽³⁾	IE3	478	277	{ 95.5 96.0 96.0 }	{ 0.80 0.88 0.86 }	1795	2.1	7.2	2.5	1.7	0.65	2.2	0.5	10.6	76
315 (420)	1490	WP-UDF355MJ ⁽²⁾ WP-DF355MJ ⁽³⁾	IE3	538	312	{ 95.7 96.1 96.1 }	{ 0.83 0.87 0.83 }	2020	2.1	7.2	2.5	1.7	0.65	2.2	0.5	11.9	79
355 (475)	1490	WP-UDF355MN ⁽²⁾ WP-DF355MN ⁽³⁾	IE3	600	348	{ 96.2 96.3 96.2 }	{ 0.83 0.88 0.88 }	2276	2.2	6.8	2.5	1.7	0.68	2.1	0.5	13.2	79
375 (430)	1490	WP-UDF355LN ⁽²⁾ WP-DF355LN ⁽³⁾	IE3	635	367	{ 96.4 96.5 96.4 }	{ 0.83 0.88 0.88 }	2405	2.4	7.4	2.6	1.8	0.75	2.3	0.6	14.6	79

⁽¹⁾ European and BS frame reference

⁽²⁾ European frame reference

⁽³⁾ BS frame reference

Performance data



1500 min⁻¹ (4 pole)

Rated power Full load speed in revolutions per minute Frame reference and size Full load current at rated voltage Efficiency Power factor Full load torque Direct on line starting torque ratio Direct on line starting current ratio Direct on line pull up torque ratio Direct on line pull up torque Star delta starting torque ratio⁽¹⁾ Star delta starting current ratio Rotor inertia Wkg Mean sound pressure level @ 1m on no load

P _N kW (hp)	n min ⁻¹	Type	IE2	I _N		η		Cos φ		M _N Nm	M _A M _N	I _A I _N	M _K M _N	M _S M _N	M _A M _N Y	I _A I _N Y	M _S M _N Y	J kgm ²	L _{PA} dB(A)
				400 V A	690 V A	1.0 P _N 0.75 P _N 0.5 P _N	1.0 P _N 0.75 P _N 0.5 P _N	1.0 P _N 0.75 P _N 0.5 P _N	1.0 P _N 0.75 P _N 0.5 P _N										
75 (100)	1480	WU-DF280SNE ⁽²⁾ W-DF250MN ⁽³⁾	IE2	135	79	94.0 95.2 94.4	0.85 0.82 0.74			484	2.4	7.4	2.7	1.9	0.72	2.3	0.54	1.4	69
90 (125)	1480	WU-DF280MNE ⁽²⁾ W-DF280SN ⁽³⁾	IE2	162	94	94.2 95.2 94.6	0.85 0.82 0.73			581	2.5	7.4	2.8	2.0	0.75	2.4	0.55	1.6	69
110 (150)	1485	WU-DF315SNE ⁽²⁾ W-DF280MN ⁽³⁾	IE2	193	112	94.5 95.3 94.6	0.87 0.84 0.77			710	2.4	7.7	2.6	2.0	0.70	2.5	0.5	3.2	71
132 (175)	1485	WU-DF315MNE ⁽²⁾ W-DF315SN ⁽³⁾	IE2	231	134	94.7 95.6 94.9	0.87 0.84 0.77			849	2.4	7.7	2.6	2.0	0.70	2.5	0.5	3.7	71
150 (200)	1490	WU-DF315MN ⁽²⁾ W-DF315MN ⁽³⁾	IE2	256	149	94.9 95.7 94.8	0.89 0.87 0.81			961	2.4	7.8	2.7	2.0	0.70	2.5	0.5	4.4	73
160 (215)	1490	WU-DF315MP ⁽²⁾ W-DF315MP ⁽³⁾	IE2	270	156	94.9 96.0 95.2	0.90 0.88 0.83			1026	2.4	7.8	2.7	2.0	0.70	2.5	0.5	4.7	73
185 (250)	1490	WU-DF315LN ⁽²⁾ W-DF315LN ⁽³⁾	IE2	312	181	95.1 96.0 95.5	0.90 0.87 0.80			1186	2.4	7.8	2.7	2.2	0.70	2.5	0.5	5.5	73
200 (270)	1485	WU-DF315LN ⁽²⁾ W-DF315LN ⁽³⁾	IE2	341	198	95.1 96.1 95.6	0.90 0.89 0.84			1284	2.3	7.6	2.6	1.9	0.65	2.4	0.45	5.5	73
225 (300)	1490	WU-DF355SG ⁽²⁾ W-DF355SG ⁽³⁾	IE2	384	222	95.1 96.1 95.4	0.89 0.87 0.80			1442	2.0	6.6	2.3	1.7	0.62	2.2	0.5	8.2	76
250 (335)	1485	WU-DF355SJ ⁽²⁾ W-DF355SJ ⁽³⁾	IE2	426	247	95.1 96.0 95.9	0.89 0.87 0.81			1608	2.0	5.7	2.5	1.7	0.62	1.8	0.5	9.5	76
280 (375)	1490	WU-DF355SN ⁽²⁾ W-DF355SN ⁽³⁾	IE2	483	279	95.1 95.7 95.3	0.89 0.84 0.77			1795	2.1	7.2	2.5	1.7	0.65	2.2	0.5	10.6	76
315 (420)	1487	WU-DF355MJ ⁽²⁾ W-DF355MJ ⁽³⁾	IE2	537	310	95.1 96.1 95.6	0.89 0.88 0.85			2023	2.1	7.2	2.5	1.7	0.65	2.2	0.5	11.9	79
355 (475)	1490	WU-DF355MN ⁽²⁾ W-DF355MN ⁽³⁾	IE2	605	349	95.1 96.0 95.1	0.89 0.89 0.84			2275	2.1	7.2	2.5	1.7	0.65	2.2	0.5	13.2	79
400 (535)	1485	WU-DF355LN ⁽²⁾ W-DF355LN ⁽³⁾	IE2	680	393	95.6 96.3 96.1	0.89 0.88 0.83			2572	2.0	6.0	2.5	1.7	0.62	1.87	0.5	14.6	79

⁽¹⁾ European and BS frame reference

⁽²⁾ European frame reference

⁽³⁾ BS frame reference

Performance data



12 1000 min⁻¹ (6 pole)

Rated power
Full load speed in revolutions per minute
Frame reference and size
Full load current at rated voltage
Efficiency
Power factor
Full load torque
Direct on line starting torque ratio
Direct on line starting current ratio
Direct on line pull up torque ratio
Direct on line pull up torque
Star-delta starting torque ratio⁽¹⁾
Star-delta starting current ratio
Star-delta pull up torque
Rotor inertia Wkg
Mean sound pressure level @ 1m on no load

P _N kW (hp)	n min ⁻¹	Type	IE3	I _N			η		Cos φ		M _N Nm	M _A M _N	I _A I _N	M _K M _N	M _S M _N	M _A M _N Y	I _A I _N Y	M _S M _N Y	J kgm ²	L _{PA} dB(A)
				230 V A	400 V A	690 V A	1.0 P _N 0.75 P _N	1.0 P _N 0.75 P _N	0.75 P _N 0.5 P _N	0.75 P _N 0.5 P _N										
0.75 (1.0)	-	tbc	IE3	-	-	-	{ - - }	{ - - }		-	-	-	-	-	-	-	-	-	-	-
1.1 (1.5)	-	tbc	IE3	-	-	-	{ - - }	{ - - }		-	-	-	-	-	-	-	-	-	-	-
1.5 (2.0)	960	WP-DF100LTF ⁽¹⁾	IE3	8.1	4.7	-	{ 82.5 0.60 }	{ 82.1 0.48 }		14.9	3.5	6.2	4.6	3.6	-	-	-	0.012	58	
2.2 (3)	960	WP-DF112MWX ⁽¹⁾	IE3	10.1	5.8	-	{ 84.3 0.65 }	{ 84.4 0.58 }		21.9	2.8	5.6	3.0	2.4	-	-	-	0.015	54	
3.0 (4.0)	970	WP-DF132SMX ⁽¹⁾	IE3	12.5	7.2	-	{ 87.0 0.69 }	{ 86.7 0.62 }		29.5	2.3	6.1	2.5	2.2	-	-	-	0.032	58	
4.0 (5.5)	960	WP-DF132MTX ⁽¹⁾	IE3	-	9.8	5.8	{ 86.8 0.68 }	{ 86.5 0.59 }		39.8	2.3	5.5	2.5	2.1	0.7	1.7	0.66	0.038	58	
5.5 (7.5)	965	WP-DF132MVX ⁽¹⁾	IE3	-	13.3	7.7	{ 88.0 0.68 }	{ 87.0 0.53 }		54.5	2.6	6.5	3.0	1.9	0.8	2.0	0.6	0.041	58	
7.5 (10)	975	WP-DF160MM ⁽¹⁾	IE3	-	16.6	9.6	{ 90.0 0.73 }	{ 89.1 0.65 }		73.5	1.7	5.1	1.6	1.3	0.53	1.6	0.4	0.10	59	
11 (15)	980	WP-DF160LV ⁽¹⁾	IE3	-	23.4	13.6	{ 90.3 0.75 }	{ 90.3 0.69 }		107	2.0	5.7	2.8	1.9	0.63	2.3	0.6	0.12	59	
15 (20)	980	WP-DF180LM ⁽¹⁾	IE3	-	30.4	17.6	{ 91.2 0.78 }	{ 91.5 0.72 }		146	2.0	6.0	2.4	1.5	0.63	1.9	0.5	0.24	59	
18.5 (25)	980	WP-UDF200LN ⁽²⁾ WP-DF200LN ⁽³⁾	IE3	-	36.4	21.0	{ 91.7 0.80 }	{ 91.7 0.73 }		180	2.7	7.9	2.8	2.8	0.84	2.5	0.88	0.37	62	
22 (30)	980	WP-UDF200LN ⁽²⁾ WP-DF200LN ⁽³⁾	IE3	-	43.6	25.3	{ 92.2 0.79 }	{ 92.2 0.73 }		215	2.0	6.8	2.3	2.2	0.63	2.2	0.7	0.9	62	
30 (40)	985	WP-UDF225MN ⁽²⁾ WP-DF225MN ⁽³⁾	IE3	-	57.5	33.4	{ 92.9 0.81 }	{ 92.9 0.77 }		291	2.7	6.0	2.1	1.8	0.80	2.0	0.45	1.23	63	
37 (50)	985	WP-UDF250MNE ⁽²⁾ WP-DF250SN ⁽³⁾	IE3	-	71	41	{ 93.5 0.81 }	{ 93.6 0.77 }		359	2.7	6.0	2.0	1.8	0.84	1.9	0.40	1.47	63	
45 (60)	990	WP-UDF280SNE ⁽²⁾ WP-DF250MN ⁽³⁾	IE3	-	85	50	{ 94.0 0.81 }	{ 94.1 0.77 }		434	2.5	6.0	2.0	1.8	0.75	1.9	0.40	2.55	65	

⁽¹⁾ European and BS frame reference

⁽²⁾ European frame reference

⁽³⁾ BS frame reference

Performance data



13

1000 min⁻¹ (6 pole)

P _N kW (hp)	n min ⁻¹	Type	I _N			η		Cos φ		M _N Nm	M _A M _N	I _A I _N	M _K M _N	M _S M _N	M _A M _N Y	I _A I _N Y	M _S M _N Y	J kgm ²	L _{PA} dB(A)
			230 V A	400 V A	690 V A	1.0 P _N 0.75 P _N	1.0 P _N 0.75 P _N	0.75 P _N 0.5 P _N	0.75 P _N 0.5 P _N										
0.37 (0.5)	920	A-DF80MG ⁽¹⁾	-	1.27	-	69.0 68.0 64.0	0.61 0.51 0.40		3.8	2.0	3.7	2.2	1.8	-	-	-	0.0015	49	
0.55 (0.75)	920	A-DF80MM ⁽¹⁾	-	1.77	-	71.0 71.0 68.0	0.63 0.54 0.41		5.7	2.0	3.7	2.3	1.8	-	-	-	0.0021	49	
0.75 (1.0)	935	WU-DF90LTX ⁽¹⁾	IE2	-	2.2	-	75.9 73.8 70.1	0.65 0.54 0.44	7.7	2.9	4.8	3.0	2.5	-	-	-	0.0039	65	
1.1 (1.5)	925	WU-DF90LWX ⁽¹⁾	IE2	5.3	3.0	-	78.1 75.6 73.1	0.67 0.57 0.42	11.4	3.0	4.8	3.0	2.6	-	-	-	0.0043	65	
1.5 (2.0)	930	WU-DF100LSF ⁽¹⁾	IE2	6.6	3.8	-	79.8 76.8 74.6	0.71 0.68 0.51	15.4	2.2	5.8	2.4	1.9	-	-	-	0.011	58	
2.2 (3)	950	WU-DF112MT ⁽¹⁾	IE2	9.6	5.5	-	81.8 77.6 73.9	0.70 0.56 0.45	22.1	2.5	6.5	2.9	2.0	-	-	-	0.012	54	
3.0 (4.0)	965	WU-DF132SL ⁽¹⁾	IE2	12.0	6.9	-	83.3 84.8 83.2	0.75 0.67 0.54	29.7	2.1	6.7	2.6	1.6	-	-	-	0.027	58	
4.0 (5.5)	960	WU-DF132MM ⁽¹⁾	IE2	-	9.3	5.4	84.6 84.8 82.5	0.74 0.66 0.54	39.8	2.2	5.9	2.5	1.6	-	-	-	0.029	58	
5.5 (7.5)	950	WU-DF132MR ⁽¹⁾	IE2	-	12.3	7.1	86.0 85.2 83.5	0.75 0.68 0.55	55.3	2.1	5.6	2.4	1.6	-	-	-	0.032	58	
7.5 (10)	975	WU-DF160MM ⁽¹⁾	IE2	-	16.6	9.6	87.2 88.1 86.2	0.75 0.67 0.56	73.5	1.8	6.5	2.8	1.7	0.55	2.1	0.5	0.10	59	
11 (15)	980	WU-DF160LV ⁽¹⁾	IE2	-	24.0	13.8	88.7 90.0 88.5	0.75 0.67 0.57	107	2.0	7.5	2.8	1.9	0.60	2.5	0.5	0.12	59	
15 (20)	980	WU-DF180LM ⁽¹⁾	IE2	-	30.5	17.6	89.7 90.8 89.6	0.78 0.74 0.63	146	2.4	6.5	2.8	2.2	0.65	2.2	0.6	0.23	59	
18.5 (25)	980	WU-DF200LGX ⁽²⁾ W-DF200LGX ⁽³⁾	IE2	-	36.5	21.0	90.4 90.8 90.0	0.81 0.76 0.65	180	2.3	7.0	2.0	2.8	0.65	2.3	0.5	0.42	62	
22 (30)	980	WU-DF200LNX ⁽²⁾ W-DF200LNX ⁽³⁾	IE2	-	42	24.5	90.9 91.1 90.5	0.83 0.78 0.68	214	2.3	7.0	2.1	2.8	0.65	2.3	0.5	0.48	62	
30 (40)	980	WU-DF225MN ⁽²⁾ W-DF225MN ⁽³⁾	IE2	-	59	34.2	91.7 92.8 92.0	0.80 0.73 0.63	292	2.7	6.0	2.1	1.8	0.80	2.0	0.45	1.23	63	
37 (50)	985	WU-DF250MNE ⁽²⁾ W-DF250SN ⁽³⁾	IE2	-	71	41	92.2 93.3 92.6	0.81 0.86 0.66	359	2.7	6.0	2.1	1.8	0.80	2.0	0.45	1.47	63	
45 (60)	985	WU-DF280SNE ⁽²⁾ W-DF250MN ⁽³⁾	IE2	-	86	50	92.7 93.4 92.8	0.81 0.82 0.80	436	2.5	6.0	2.0	1.8	0.75	1.9	0.40	2.55	65	

⁽¹⁾ European and BS frame reference

⁽²⁾ European frame reference

⁽³⁾ BS frame reference

Performance data



14 1000 min⁻¹ (6 pole)

Rated power Full load speed in revolutions per minute Frame reference and size Full load current at rated voltage Efficiency Power factor Full load torque Direct on line starting torque ratio Direct on line starting current ratio Direct on line pull out torque ratio Direct on line pull up torque Star-delta starting torque ratio⁽¹⁾ Star-delta starting current ratio Rotor inertia Wkg Mean sound pressure level @ 1m on no load

P _N kW (hp)	n min ⁻¹	Type	IE3	I _N		η		Cos φ		M _N Nm	M _A M _N	I _A I _N	M _K M _N	M _S M _N	M _A M _N Y	I _A I _N Y	M _S M _N Y	J kgm ²	L _{PA} dB(A)
				400 V A	690 V A	1.0 P _N 0.75 P _N 0.5 P _N	1.0 P _N 0.75 P _N 0.5 P _N	1.0 P _N 0.75 P _N 0.5 P _N	1.0 P _N 0.75 P _N 0.5 P _N										
55 (75)	990	WP-UDF280MNE ⁽²⁾ WP-DF280SN ⁽³⁾	IE3	104	60	94.1 94.1 93.2	0.81 0.78 0.71	531	2.5	6.1	2.0	1.9	0.75	1.85	0.40	2.9	65		
75 (100)	990	WP-UDF315SNE ⁽²⁾ WP-DF280MN ⁽³⁾	IE3	138	80	94.6 94.6 93.5	0.83 0.80 0.70	724	3.0	7.0	2.6	2.1	0.90	2.1	0.60	5.0	68		
90 (125)	990	WP-UDF315MNE ⁽²⁾ WP-DF315SN ⁽³⁾	IE3	165	95	94.9 94.9 93.0	0.83 0.77 0.67	869	3.0	7.0	2.6	2.1	0.90	2.1	0.60	6.0	68		
110 (150)	988	WP-UDF315MN ⁽²⁾ WP-DF315MN ⁽³⁾	IE3	196	114	95.4 95.5 95.0	0.85 0.83 0.77	1064	2.8	6.7	2.0	1.9	0.80	2.1	0.55	6.1	78		
132 (175)	985	WP-UDF315LN ⁽²⁾ WP-DF315LN ⁽³⁾	IE3	235	136	95.4 95.4 94.5	0.85 0.82 0.75	1280	2.8	6.7	2.5	2.4	0.80	2.1	0.75	7.3	70		
150 (200)	987	WP-UDF355SG ⁽²⁾ WP-DF355SG ⁽³⁾	IE3	270	156	95.5 95.5 94.7	0.84 0.82 0.74	1452	1.7	7.0	2.1	1.4	0.50	2.2	0.35	10	74		
160 (215)	990	WP-UDF355SG ⁽²⁾ WP-DF355SG ⁽³⁾	IE3	295	171	95.8 95.9 94.9	0.82 0.77 0.69	1544	1.7	6.7	2.1	1.4	0.50	2.0	0.35	10	74		
185 (250)	990	WP-UDF355SJ ⁽²⁾ WP-DF355SJ ⁽³⁾	IE3	328	190	95.7 95.8 95.0	0.85 0.84 0.77	1785	1.7	6.7	2.1	1.4	0.45	2.1	0.35	11.1	74		
200 (270)	-	tbc tbc	IE3	-	-	- - -	- - -	-	-	-	-	-	-	-	-	-	-		
225 (300)	990	WP-UDF355MJ ⁽²⁾ WP-DF355MJ ⁽³⁾	IE3	394	229	95.8 93.7 93.5	0.86 0.82 0.74	2170	1.7	6.7	2.1	1.4	0.45	2.1	0.35	10.3	77		
250 (335)	990	WP-UDF355MN ⁽²⁾ WP-DF355MN ⁽³⁾	IE3	446	258	96.2 96.3 95.9	0.84 0.81 0.74	2413	1.8	7.0	2.2	1.5	0.48	2.2	0.40	15.2	77		
280 (375)	990	WP-UDF355LJ ⁽²⁾ WP-DF355LJ ⁽³⁾	IE3	491	284	95.8 95.9 95.4	0.86 0.79 0.69	2702	1.8	7.0	2.2	1.5	0.48	2.2	0.40	16.9	77		
315 (420)	990	WP-UDF355LN ⁽²⁾ WP-DF355LN ⁽³⁾	IE3	552	320	95.8 95.9 95.5	0.86 0.84 0.77	3040	1.8	7.0	2.1	1.5	0.48	2.1	0.40	18.6	77		

⁽¹⁾ European and BS frame reference
⁽²⁾ European frame reference
⁽³⁾ BS frame reference

Performance data



15

1000 min⁻¹ (6 pole)

Rated power Full load speed in revolutions per minute Frame reference and size Full load current at rated voltage Efficiency Power factor Full load torque Direct on line starting torque ratio Direct on line starting current ratio Direct on line pull up torque ratio Direct on line pull up torque Star delta starting torque ratio (I) Star delta starting current ratio Rotor inertia Wkg Mean sound pressure level @ 1m on no load

P _N kW (hp)	n min ⁻¹	Type	IE2	I _N		η		Cos φ		M _N Nm	M _A M _N	I _A I _N	M _K M _N	M _S M _N	M _A M _N Y	I _A I _N Y	M _S M _N Y	J kgm ²	L _{PA} dB(A)
				400 V A	690 V A	1.0 P _N 0.75 P _N 0.5 P _N	1.0 P _N 0.75 P _N 0.5 P _N	1.0 P _N 0.75 P _N 0.5 P _N	1.0 P _N 0.75 P _N 0.5 P _N										
55 (75)	985	WU-DF280MNE ⁽²⁾ W-DF280SN ⁽³⁾	IE2	103	60	93.1 94.1 93.8	0.83 0.80 0.74	533	2.5	6.1	2.0	1.9	0.75	1.85	0.40	2.9	65		
75 (100)	990	WU-DF315SNE ⁽²⁾ W-DF280MN ⁽³⁾	IE2	139	81	93.7 94.4 93.3	0.83 0.79 0.70	724	3.0	7.0	2.6	2.1	0.90	2.1	0.60	5.0	68		
90 (125)	990	WU-DF315MNE ⁽²⁾ W-DF315SN ⁽³⁾	IE2	165	95	94.0 94.3 93.4	0.84 0.80 0.72	873	3.0	7.0	2.6	2.1	0.90	2.1	0.60	6.0	68		
110 (150)	985	WU-DF315MN ⁽²⁾ W-DF315MN ⁽³⁾	IE2	198	114	94.3 94.7 93.8	0.85 0.81 0.73	1066	2.8	6.7	2.0	1.9	0.80	2.1	0.55	6.1	70		
132 (175)	985	WU-DF315LN ⁽²⁾ W-DF315LN ⁽³⁾	IE2	237	137	94.6 94.9 94.1	0.85 0.81 0.73	1280	2.8	6.7	2.0	1.9	0.80	2.1	0.55	7.3	70		
150 (200)	987	WU-DF355SG ⁽²⁾ W-DF355SG ⁽³⁾	IE2	272	157	94.7 95.4 94.5	0.84 0.83 0.76	1451	1.7	7.0	2.1	1.4	0.50	2.2	0.35	10	74		
160 (215)	990	WU-DF355SG ⁽²⁾ W-DF355SG ⁽³⁾	IE2	287	166	94.8 95.4 94.5	0.85 0.83 0.76	1551	1.7	6.7	2.1	1.4	0.50	2.0	0.35	10	74		
185 (250)	990	WU-DF355SJ ⁽²⁾ W-DF355SJ ⁽³⁾	IE2	331	191	94.9 95.8 95.1	0.85 0.83 0.76	1785	1.7	6.7	2.1	1.4	0.45	2.1	0.35	11.1	74		
200 (270)	990	WU-DF355SN ⁽²⁾ W-DF355SN ⁽³⁾	IE2	358	207	95.0 95.9 95.2	0.85 0.83 0.76	1939	1.7	6.7	2.1	1.4	0.45	2.1	0.35	12.2	74		
225 (300)	990	WU-DF355MJ ⁽²⁾ W-DF355MJ ⁽³⁾	IE2	398	230	95.0 96.0 95.4	0.86 0.83 0.76	2170	1.7	6.7	2.1	1.4	0.45	2.1	0.35	13.6	77		
250 (335)	990	WU-DF355MN ⁽²⁾ W-DF355MN ⁽³⁾	IE2	442	255	95.0 95.0 94.3	0.86 0.84 0.77	2412	1.8	7.0	2.2	1.5	0.48	2.2	0.40	15.2	77		
280 (375)	990	WU-DF355LJ ⁽²⁾ W-DF355LJ ⁽³⁾	IE2	495	286	95.0 95.2 94.9	0.86 0.84 0.77	2701	1.8	7.0	2.2	1.5	0.48	2.2	0.40	16.9	77		
315 (420)	990	WU-DF355LN ⁽²⁾ W-DF355LN ⁽³⁾	IE2	557	322	95.0 95.3 94.7	0.86 0.84 0.77	3039	1.8	7.0	2.1	1.5	0.48	2.1	0.40	18.6	77		

⁽¹⁾ European and BS frame reference

⁽²⁾ European frame reference

⁽³⁾ BS frame reference

Performance data

16

750 min⁻¹ (8 pole)

P _N kW (hp)	n min ⁻¹	Type	I _N			η		Cos φ		M _N Nm	M _A M _N	I _A I _N	M _K M _N	M _S M _N	M _A M _N Y	I _A I _N Y	M _S M _N Y	J kgm ²	L _{PA} dB(A)
			380 V A	400 V A	415 V A	1.0 P _N 0.75 P _N 0.5 P _N	1.0 P _N 0.75 P _N 0.5 P _N												
0.18 (0.25)	695	W-DF80MG ⁽¹⁾	1.01	0.96	0.96	{ 55.0 52.0 44.0 }	{ 0.49 0.42 0.34 }		2.5	2.2	2.7	2.5	2.0	-	-	-	0.0017	46	
0.25 (0.33)	695	W-DF80MM ⁽¹⁾	1.26	1.2	1.2	{ 59.0 56.5 49.0 }	{ 0.51 0.43 0.34 }		3.5	2.2	2.9	2.5	2.0	-	-	-	0.0021	46	
0.37 (0.5)	700	W-DF90SG ⁽¹⁾	1.71	1.63	1.63	{ 62.0 59.0 51.0 }	{ 0.53 0.44 0.34 }		5.1	2.3	3.0	2.5	2.1	-	-	-	0.0028	50	
0.55 (0.75)	680	W-DF90LM ⁽¹⁾	2.4	2.3	2.3	{ 64.0 62.0 55.0 }	{ 0.54 0.44 0.33 }		7.6	2.3	3.3	2.7	2.1	-	-	-	0.0035	50	
0.75 (1)	690	W-DF100LR ⁽¹⁾	2.77	2.64	2.64	{ 69.5 68.0 61.0 }	{ 0.59 0.49 0.40 }		10.4	1.8	3.2	2.1	1.7	-	-	-	0.009	53	
1.1 (1.5)	690	W-DF100LS ⁽¹⁾	3.9	3.7	3.7	{ 71.5 70.5 68.0 }	{ 0.60 0.51 0.39 }		15.2	1.8	3.2	2.1	1.7	-	-	-	0.0095	53	
1.5 (2)	690	W-DF112MS ⁽¹⁾	4.6	4.4	4.4	{ 74.5 74.0 71.0 }	{ 0.66 0.56 0.44 }		20.7	1.9	4.0	2.0	1.7	-	-	-	0.015	57	
2.2 (3)	720	W-DF132SM ⁽¹⁾	6.2	5.9	5.9	{ 82.5 83.0 80.0 }	{ 0.65 0.57 0.45 }		29.2	1.6	5.0	2.4	1.5	-	-	-	0.029	57	
3 (4)	720	W-DF132MR ⁽¹⁾	8.2	7.8	7.8	{ 84.0 84.0 82.0 }	{ 0.66 0.58 0.45 }		39.8	1.6	5.0	2.4	1.4	-	-	-	0.031	57	
4 (5.5)	725	W-DF160ME ⁽¹⁾	10.4	9.9	9.9	{ 86.0 86.0 84.0 }	{ 0.68 0.64 0.51 }		52.7	1.6	5.5	2.5	1.4	0.5	1.7	0.45	0.09	53	
5.5 (7.5)	725	W-DF160MM ⁽¹⁾	13.9	13.2	13.2	{ 87.0 87.0 85.5 }	{ 0.69 0.65 0.52 }		72.4	1.6	5.7	2.5	1.4	0.5	1.7	0.45	0.11	53	
7.5 (10)	725	W-DF160LV ⁽¹⁾	18.2	17.3	17.3	{ 88.0 88.0 86.0 }	{ 0.71 0.65 0.52 }		98.8	1.6	6.0	2.5	1.4	0.5	1.8	0.45	0.14	53	
11 (15)	730	W-DF180LM ⁽¹⁾	27.6	26.3	26.3	{ 90.0 90.0 88.0 }	{ 0.67 0.59 0.48 }		143.9	2.0	4.5	2.5	1.7	0.63	1.4	0.55	0.24	58	
15 (20)	730	WU-DF200LN ⁽²⁾ W-DF200LN ⁽³⁾	35	33	32	{ 90.0 90.0 88.5 }	{ 0.73 0.66 0.54 }		196	1.8	5.8	2.6	1.6	0.45	1.7	0.35	0.48	60	
18.5 (25)	730	WU-DF225SN ⁽²⁾ W-DF225SN ⁽³⁾	43	40	39	{ 90.5 90.5 89.5 }	{ 0.73 0.66 0.54 }		242	2.0	5.5	2.25	1.6	0.5	1.6	0.35	0.75	60	
22 (30)	730	WU-DF225MN ⁽²⁾ W-DF225MN ⁽³⁾	50	47	45	{ 91.5 91.5 89.0 }	{ 0.74 0.66 0.54 }		288	2.0	6.0	2.4	1.6	0.45	1.7	0.35	1.23	62	
30 (40)	735	WU-DF250MNE ⁽²⁾ W-DF250SN ⁽³⁾	67	64	61	{ 92.0 92.0 90.0 }	{ 0.74 0.67 0.55 }		390	1.7	6.0	2.4	1.6	0.4	1.7	0.35	1.47	62	

⁽¹⁾ European and BS frame reference

⁽²⁾ European frame reference

⁽³⁾ BS frame reference

Performance data

750 min⁻¹ (8 pole)

17

Rated power P_N kW (hp)	Full load speed in revolutions per minute n min ⁻¹	Frame reference and size Type	Full load current at rated voltage I_N			Efficiency η		Power factor $\cos \phi$	Full load torque M_N Nm	Direct on line starting torque ratio $\frac{M_A}{M_N}$	Direct on line starting current ratio $\frac{I_A}{I_N}$	Direct on line pull up torque ratio $\frac{M_K}{M_N}$	Direct on line pull up torque ratio $\frac{M_S}{M_N}$	Star delta starting torque ratio ⁽¹⁾ $\frac{M_A}{M_N}$ Y	Star delta starting current ratio ⁽¹⁾ $\frac{I_A}{I_N}$ Y	Star delta pull up torque ratio $\frac{M_S}{M_N}$ Y	Rotor inertia I_{Wk} J kgm ²	Mean sound pressure level @ 1m on no load L_{PA} dB(A)
			380 V A	400 V A	415 V A	1.0 P_N 0.75 P_N 0.5 P_N	1.0 P_N 0.75 P_N 0.5 P_N											
37 (50)	735	WU-DF280SNE ⁽²⁾ W-DF250MN ⁽³⁾	81	77	74	92.5 92.5 91.5	0.75 0.68 0.56	481	1.7	6.0	2.4	1.6	0.40	1.7	0.35	2.55	63	
45 (60)	735	WU-DF280MNE ⁽²⁾ W-DF280SN ⁽³⁾	98	93	90	93.0 92.8 91.6	0.75 0.69 0.57	585	1.7	6.0	2.4	1.4	0.40	1.7	0.3	2.9	63	
55 (75)	740	WU-DF315SNE ⁽²⁾ W-DF280MN ⁽³⁾	119	113	109	93.5 93.3 92.0	0.75 0.70 0.58	710	2.5	6.0	2.0	1.5	0.60	1.7	0.35	5.0	64	
75 (100)	740	WU-DF315MNE ⁽²⁾ W-DF315SN ⁽³⁾	159	151	146	94.1 93.9 92.2	0.76 0.72 0.60	968	2.5	6.0	2.0	1.5	0.60	1.7	0.35	6.0	64	
90 (125)	740	WU-DF315MN ⁽²⁾ W-DF315MN ⁽³⁾	188	179	172	94.4 94.2 93.4	0.77 0.73 0.64	1161	2.4	6.0	2.0	1.8	0.65	1.7	0.45	6.1	65	
110 (150)	740	WU-DF315LN ⁽²⁾ W-DF315LN ⁽³⁾	227	218	210	94.6 94.4 93.6	0.77 0.73 0.64	1419	2.4	6.0	2.0	1.8	0.65	1.7	0.45	7.3	65	
132 (175)	740	WU-DF355SJ ⁽²⁾ W-DF355SJ ⁽³⁾	274	260	251	95.1 94.8 93.6	0.77 0.73 0.64	1703	1.6	6.1	2.0	1.3	0.40	1.8	0.3	12.2	72	
150 (200)	740	WU-DF355SN ⁽²⁾ W-DF355SN ⁽³⁾	310	295	284	95.5 95.3 94.0	0.77 0.73 0.64	1936	1.6	6.1	2.0	1.3	0.40	1.8	0.3	13.6	72	
160 (215)	740	WU-DF355SN ⁽²⁾ W-DF355SN ⁽³⁾	331	315	303	95.5 95.3 94.0	0.77 0.73 0.64	2065	1.6	6.1	2.0	1.3	0.40	1.8	0.3	13.6	72	
185 (250)	740	WU-DF355MJ ⁽²⁾ W-DF355MJ ⁽³⁾	383	364	350	95.6 95.4 94.1	0.77 0.73 0.64	2387	1.6	6.1	2.0	1.3	0.40	1.8	0.3	15.2	74	
200 (270)	740	WU-DF355MN ⁽²⁾ W-DF355MN ⁽³⁾	413	393	378	95.6 95.4 94.3	0.77 0.73 0.64	2581	1.6	6.1	2.0	1.3	0.40	1.8	0.3	16.9	74	
225 (300)	740	WU-DF355LN ⁽²⁾ W-DF355LN ⁽³⁾	464	441	425	95.6 95.4 94.7	0.77 0.73 0.64	2903	1.6	6.1	2.0	1.3	0.40	1.8	0.3	18.6	74	

⁽¹⁾ European and BS frame reference
⁽²⁾ European frame reference
⁽³⁾ BS frame reference

Dimensions - European & BS specifications

18

Foot, flange and face mounting - frame sizes 80 to 180

IM B3
IM 1001
Mounting options

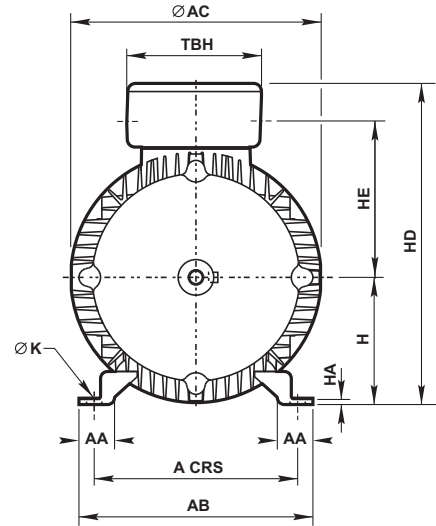
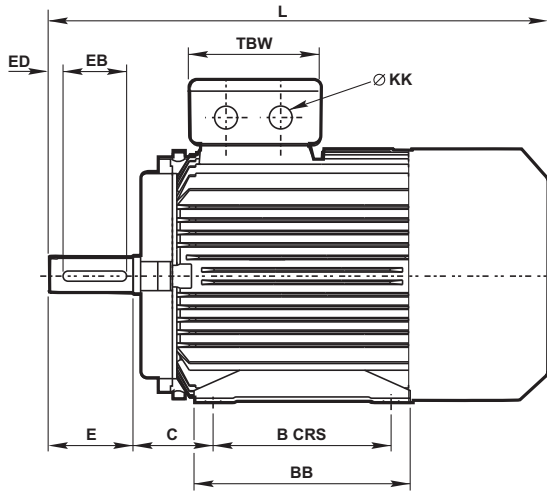

IM B5/IM B35
IM 3001/IM 2001
Mounting options

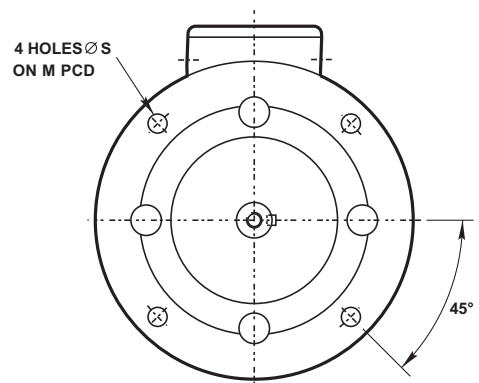
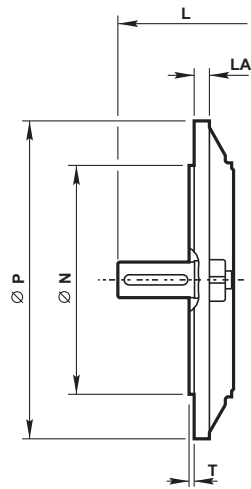

IM B14/IM B34
IM 3601/IM 2101
Mounting options

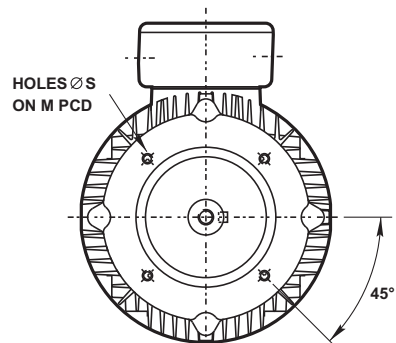
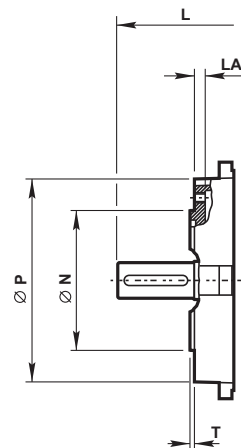

Dimensions- European & BS specifications

Foot, flange and face mounting - frame sizes 80 to 180

General Type	A	B	C	H	K	Pole				Terminal box			HA	HD	HE	TBW	TBH	KK	
						2 pole	4 pole	6 pole	8 pole	AA	AB	AC							BB
WU-DF80M	125	100	50	80	10	278	278	278	278	35	157	158	127	10	159*	118*	120	120	1 X 20
WU-DF90S	140	100	56	90	10	-	-	-	322	38	175	175	155	12	179*	123*	120	120	1 X 20
WU-DF90L	140	125	56	90	10	364	364	364	322	38	175	174	195	12	254	123	120	120	1 X 20
WU-DF100L	160	140	63	100	12	368	368	-	368	34	195	197	206	14	274	133	120	120	2 X 20
WU-DF100LF	160	140	63	100	12	-	409	409	-	34	195	214	206	14	283	142	120	120	2 X 20
WU-DF112M	190	140	70	112	12	382	382	382	382	40	230	220	182	16	305	145	135	135	2 X 25
WU-DF132S	216	140	89	132	12	447	485	447	447	47	255	256	220	16	348	168	135	135	2 X 25
WU-DF132M	216	178	89	132	12	447	485	447	447	47	255	256	220	16	348	168	135	135	2 X 25
WU-DF160M	254	210	108	160	15	604	604	604	604	55	300	315	300	22	428	208	174	174	2 X 32
WU-DF160L	254	254	108	160	15	604	604	604	604	55	300	315	300	22	428	208	174	174	2 X 32
WU-DF180M	279	241	121	180	15	663	663	663	663	64	344	355	326	22	469	230	174	174	2 X 32
WU-DF180L	279	279	121	180	15	663	663	663	663	64	344	355	326	22	469	230	174	174	2 X 32

* All 80 frame motors and the 90 frame 8 pole motor have the terminal box mounted on the right hand side when viewed on DE. Dimension 'HD' is the top of the motor when terminal box R.H.S and dimension 'HE' is the centre line of the motor to the centre line of the cable entry position.

Flange & Face Type	IM B5 mounting						IM B14 mounting					
	M	N	P	S	T	LA	M	N	P	S	T	LA
	WU-DF80M	165	130	200	12	3.5	12	100	80	120	M6	3
WU-DF90S/L	165	130	200	12	3.5	12	115	95	140	M8	3	9
WU-DF100L	215	180	250	15	4	12	130	110	160	M8	3.5	12.5
WU-DF112M	215	180	250	15	4	12	130	110	164	M8	3.5	13
WU-DF132S	265	230	300	15	4	12	165	130	200	M10	3.5	14
WU-DF132M	265	230	300	15	4	12	165	130	200	M10	3.5	14
WU-DF160M	300	250	350	19	5	13	215	180	250	M12	4	13
WU-DF160L	300	250	350	19	5	13	215	180	250	M12	4	13
WU-DF180M	300	250	350	19	5	15	-	-	-	-	-	-
WU-DF180L	300	250	350	19	5	15	-	-	-	-	-	-

Shaft Type	D	E	F	G	GD	EB	ED	DH
	WU-DF80M	19	40	6	15.5	6	32	4
WU-DF90S/L	24	50	8	20	7	40	5	M8 x 19
WU-DF100L	28	60	8	24	7	50	5	M10 x 22
WU-DF112M	28	60	8	24	7	50	5	M10 x 22
WU-DF132S	38	80	10	33	8	70	5	M12 x 28
WU-DF132M	38	80	10	33	8	70	5	M12 x 28
WU-DF160M	42	110	12	37	8	100	5	M16 x 36
WU-DF160L	42	110	12	37	8	100	5	M16 x 36
WU-DF180M	48	110	14	42.5	9	100	5	M16 x 36
WU-DF180L	48	110	14	42.5	9	100	5	M16 x 36

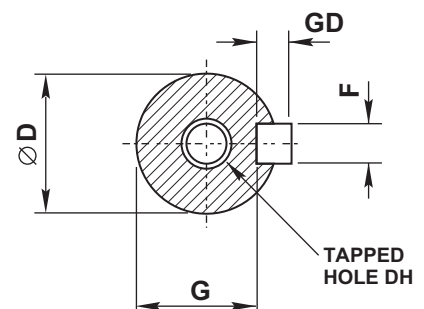

Dimensions - European specification

20

Foot and flange mounting - frame sizes 200 to 355L

IM B3
IM 1001
Mounting options

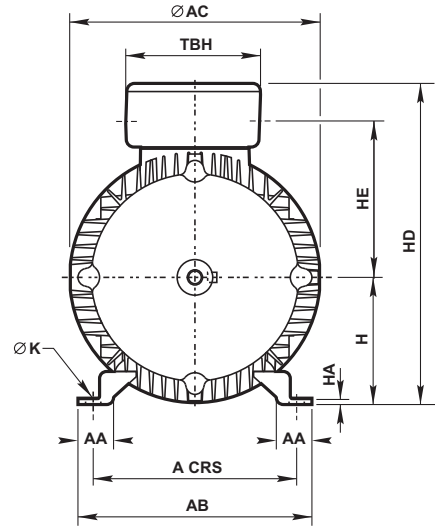
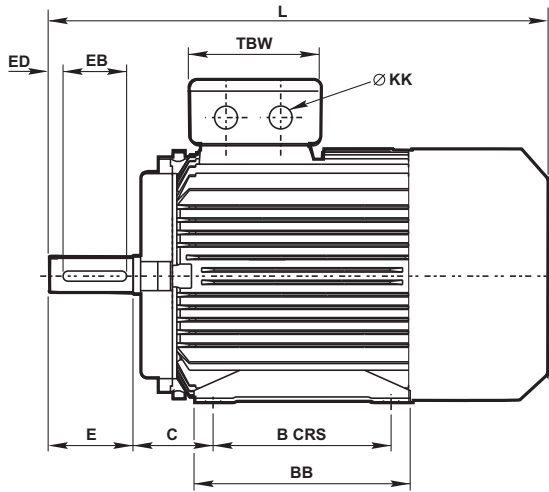

IM B5/IM B35
IM 3001/IM 2001
Mounting options

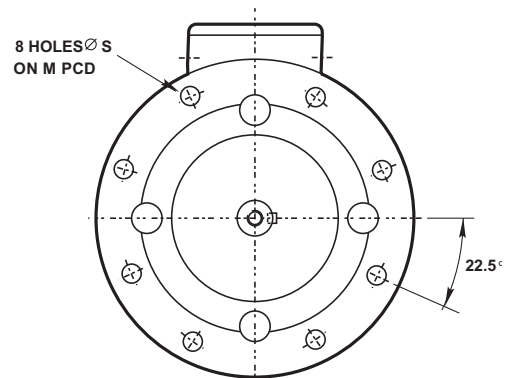
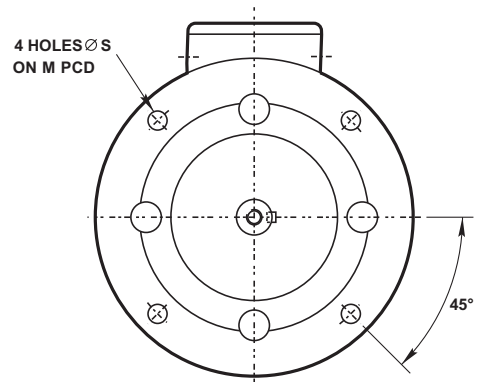
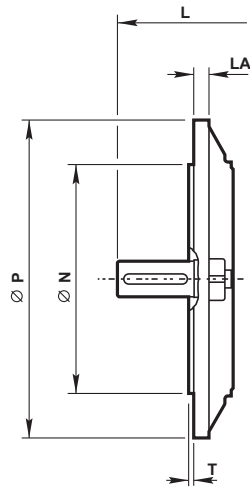

8 holes at 22.5° for flanges to suit 225 frames and above to European specification

Dimensions - European specification

Foot and flange mounting - frame sizes 200 to 355L

General																			
Type	A	B	C	H	K	4 pole +		2 pole		AA	AB	AC	BB	HA	HD	HD'	Terminal box		KK
						L	L	TBW	TBH										
WU-DF200LX	318	305	133	200	M16	787	787	74	382	381	359	30	501	444	176	220	2 x M32 + 1 x M20		
WU-DF225S	356	286	149	225	M16	875	845	70	426	410	349	25	550 ⁽¹⁾	488	220	288	2 x M40 + 1 x M20		
WU-DF225M	356	311	149	225	M16	915	885	70	426	448	374	25	570	510	220	288	2 x M40 + 1 x M20		
WU-DF250ME	406	349	168	250	M20	985	985	79	482	448	419	28	595 ⁽²⁾	535	220	288	2 x M50 + 1 x M20		
WU-DF280SE	457	368	190	280	M20	1065	1065	83	540	508	438	35	655 ⁽¹⁾	595	220	288	2 x M50 + 1 x M20		
WU-DF280ME	457	419	190	280	M20	1070	1070	83	540	508	489	35	655 ⁽¹⁾	595	220	288	2 x M50 + 1 x M20		
WU-DF315SE	508	406	216	315	M24	1145	1115	89	597	563	482	38	845	744	330	526	2 x M63 + 1 x M20		
WU-DF315ME	508	457	216	315	M24	1215	1185	89	597	563	533	38	845	744	330	526	2 x M63 + 1 x M20		
WU-DF315M	508	457	216	315	M24	1245	1215	89	597	640	533	38	875	776	330	526	2 x M63 + 1 x M20		
WU-DF315L	508	508	216	315	M24	1315	1285	89	597	640	583	38	875	776	330	526	2 x M63 + 1 x M20		
WU-DF355S	610	500	254	355	M24	1485	1415	100	710	732	626	27	975	874	330	526	2 x M63 + 1 x M20		
WU-DF355M	610	560	254	355	M24	1605	1535	100	710	732	686	27	975	874	330	526	2 x M63 + 1 x M20		
WU-DF355L	610	630	254	355	M24	1655	1585	100	710	732	756	27	975	874	330	526	2 x M63 + 1 x M20		

Shaft																	
Type	4 pole +								2 pole								
	D	E	F	G	GD	EB	ED	DH	D	E	F	G	GD	EB	ED	DH	
WU-DF200LX	55	110	16	49	10	100	5	M20 x 42	55	110	16	49	10	100	5	M20 x 42	
WU-DF225S	60	140	18	53	11	125	10	M20 x 42	55	110	16	49	10	100	5	M20 x 42	
WU-DF225M	60	140	18	53	11	125	10	M20 x 42	55	110	16	49	10	100	5	M20 x 42	
WU-DF250ME	65	140	18	58	11	125	10	M20 x 42	60	140	18	53	11	125	10	M20 x 42	
WU-DF280SE	75	140	20	67.5	12	125	10	M20 x 42	65	140	18	53	11	125	10	M20 x 42	
WU-DF280ME	75	140	20	67.5	12	125	10	M20 x 42	65	140	18	58	11	125	10	M20 x 42	
WU-DF315SE	80	170	22	71	14	160	5	M20 x 42	65	140	18	58	11	125	10	M20 x 42	
WU-DF315ME	80	170	22	71	14	160	5	M20 x 42	65	140	18	58	11	125	10	M20 x 42	
WU-DF315M	80	170	22	71	14	160	5	M20 x 42	65	140	18	58	11	125	10	M20 x 42	
WU-DF315L	80	170	22	71	14	160	5	M20 x 42	65	140	18	58	11	125	10	M20 x 42	
WU-DF355S	100	210	28	90	16	200	5	M24 x 50	75	140	20	67.5	12	125	10	M24 x 50	
WU-DF355M	100	210	28	90	16	200	5	M24 x 50	75	140	20	67.5	12	125	10	M24 x 50	
WU-DF355L	100	210	28	90	16	200	5	M24 x 50	75	140	20	67.5	12	125	10	M24 x 50	

Flange						
IM B5, IM B35 mounting						
Type	M	N	P	S	T	LA
WU-DF200LX	350	300	400	19	5	19
WU-DF225S	400	350	450	19	5	19
WU-DF225M	400	350	450	19	5	19
WU-DF250ME	500	450	550	19	5	25
WU-DF280SE	500	450	550	19	5	25
WU-DF280ME	500	450	550	19	5	25
WU-DF315SE	600	550	660	24	6	29
WU-DF315ME	600	550	660	24	6	29
WU-DF315M	600	550	660	24	6	29
WU-DF315L	600	550	660	24	6	29
WU-DF355S	740	680	800	24	6	28
WU-DF355M	740	680	800	24	6	28
WU-DF355L	740	680	800	24	6	28

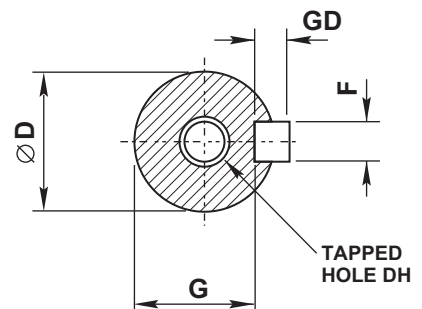

⁽¹⁾ add 25mm when cable entry is facing drive end
⁽²⁾ add 50mm when cable entry is facing drive end

Dimensions - BS specification

22

Foot and flange mounting - frame sizes 200 to 355L

IM B3
IM 1001
Mounting options

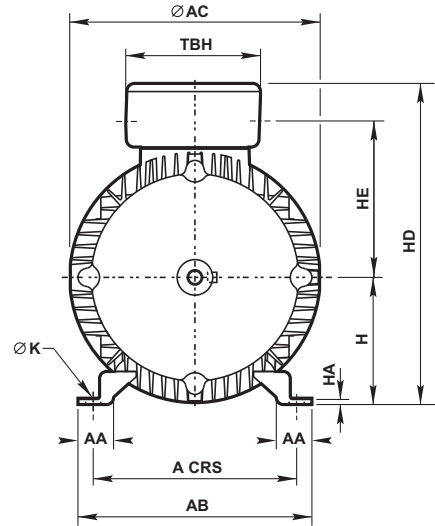
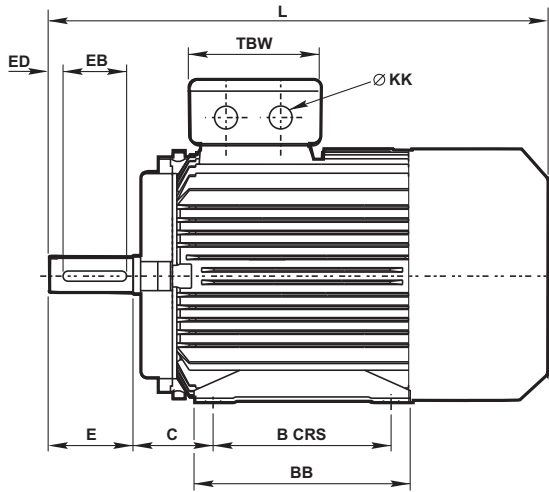

IM B5/IM B35
IM 3001/IM 2001
Mounting options

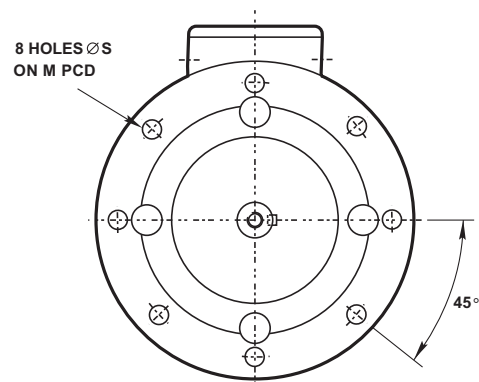
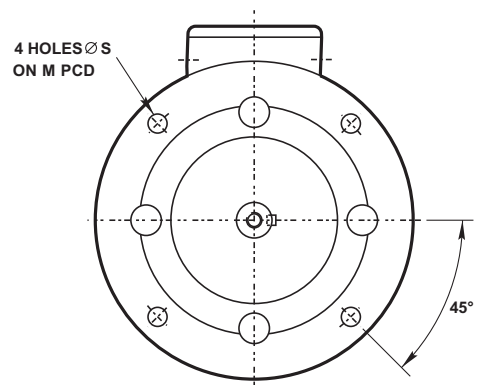
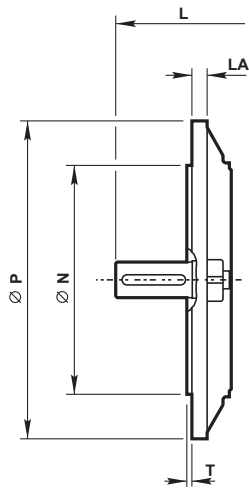

8 holes at 0° for flanges to suit 225 frames and above to British specification

Dimensions - BS specification

Foot and flange mounting - frame sizes 200 to 355L

General															
Type	A	B	C	H	K	4 pole +		AA	AB	AC	BB	HA	HD	Terminal box	
						L	L							TBW	TBH
W-DF200LX	318	305	133	200	M16	787	787	74	382	381	359	30	501	176	220
W-DF225S	356	286	149	225	M16	875	845	70	426	410	349	25	550 ⁽¹⁾	220	288
W-DF225M	356	311	149	225	M16	915	885	70	426	448	374	25	570	220	288
W-DF250S	406	311	168	250	M20	985	985	79	482	448	381	28	595 ⁽²⁾	220	288
W-DF250M	406	349	168	250	M20	1030	1030	79	482	508	419	28	625 ⁽¹⁾	220	288
W-DF280S	457	368	190	280	M20	1100	1070	83	540	508	438	35	655 ⁽¹⁾	220	288
W-DF280M	457	419	190	280	M20	1145	1115	83	540	563	487	35	810	330	526
W-DF315S	508	406	216	315	M24	1215	1185	89	597	563	483	38	845	330	526
W-DF315M	508	457	216	315	M24	1245	1215	89	597	640	533	38	875	330	526
W-DF315L	508	508	216	315	M24	1315	1285	89	597	640	583	38	875	330	526
W-DF355S	610	500	254	355	M24	1485	1415	100	710	732	626	27	970	330	526
W-DF355M	610	560	254	355	M24	1605	1535	100	710	732	686	27	970	330	526
W-DF355L	610	630	254	355	M24	1655	1585	100	710	732	756	27	970	330	526

Shaft																	
Type	4 pole +								2 pole								
	D	E	F	G	GD	EB	ED	DH	D	E	F	G	GD	EB	ED	DH	
W-DF200LX	55	110	16	49	10	100	5	M20 x 42	55	110	16	49	10	100	5	M20 x 42	
W-DF225S	60	140	18	53	11	125	10	M20 x 42	55	110	16	49	10	100	5	M20 x 42	
W-DF225M	60	140	18	53	11	125	10	M20 x 42	55	110	16	49	10	100	5	M20 x 42	
W-DF250S	70	140	20	62.5	12	125	10	M20 x 42	60	140	18	53	11	125	10	M20 x 42	
W-DF250M	70	140	20	62.5	12	125	10	M20 x 42	60	140	18	53	11	125	10	M20 x 42	
W-DF280S	80	170	22	71	14	160	5	M20 x 42	65	140	18	58	11	125	10	M20 x 42	
W-DF280M	80	170	22	71	14	160	5	M20 x 42	65	140	18	58	11	125	10	M20 x 42	
W-DF315S	85	170	22	76	14	160	5	M20 x 42	65	140	18	58	11	125	10	M20 x 42	
W-DF315M	85	170	22	76	14	160	5	M20 x 42	65	140	18	58	11	125	10	M20 x 42	
W-DF315L	85	170	22	76	14	160	5	M20 x 42	65	140	18	58	11	125	10	M20 x 42	
W-DF355S	100	210	28	90	16	200	5	M24 x 50	75	140	20	67.5	12	125	10	M24 x 50	
W-DF355M	100	210	28	90	16	200	5	M24 x 50	75	140	20	67.5	12	125	10	M24 x 50	
W-DF355L	100	210	28	90	16	200	5	M24 x 50	75	140	20	67.5	12	125	10	M24 x 50	

Flange							
IM B5, IM B35 mounting							
Type	M	N	P	S	T	LA	
W-DF200LX	350	300	400	19	5	19	
W-DF225S	400	350	450	19	5	19	
W-DF225M	400	350	450	19	5	19	
W-DF250S	500	450	550	19	5	25	
W-DF250M	500	450	550	19	5	25	
W-DF280S	500	450	550	19	5	25	
W-DF280M	500	450	550	19	5	25	
W-DF315S	600	550	660	24	6	29	
W-DF315M	600	550	660	24	6	29	
W-DF315L	600	550	660	24	6	29	
W-DF355S	740	680	800	24	6	28	
W-DF355M	740	680	800	24	6	28	
W-DF355L	740	680	800	24	6	28	

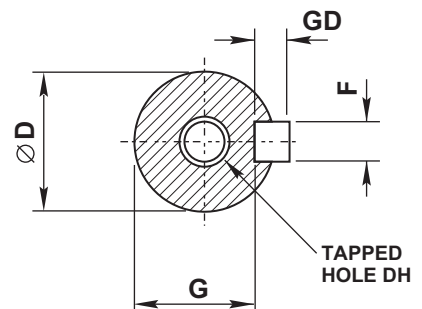

⁽¹⁾ add 25mm when cable entry is facing drive end
⁽²⁾ add 50mm when cable entry is facing drive end

Mounting options

24

Horizontal shaft:

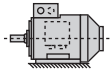

**IM B3
IM 1001**
foot mounted

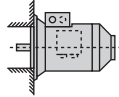

**IM B5
IM 3001**
flange at DE
no feet



**IM B6
IM 1051**
foot wall mounted with
feet on left-hand side
when viewed from DE



**IM B7
IM 1061**
foot wall mounted with
feet on right-hand side
when viewed from DE



**IM B8
IM 1071**
ceiling mounted
with feet
above motor

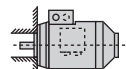

**IM B14
IM 3601**
face at DE
no feet

Vertical shaft:

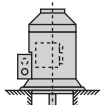

**IM V1
IM 3011**
flange at DE
shaft down
no feet

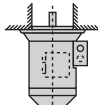

**IM V3
IM 3031**
flange at DE
shaft up
no feet

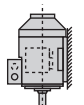

**IM V5
IM 1011**
vertical foot
wall mounted
shaft down

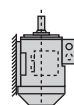

**IM V6
IM 1031**
vertical foot
wall mounted
shaft up

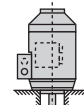

**IM V18
IM 3611**
face at DE
shaft down
no feet

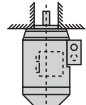

**IM V19
IM 3631**
face at DE
shaft up
no feet

Approximate shipping specifications

Type		Net weight (kg)	Gross weight (kg)	Cubage (m ³)
European	BS			
WU-DF80M	WU-DF80M	15	16.5	0.02
WU-DF90S	WU-DF90S	19	20.5	0.03
WU-DF90L	WU-DF90L	30.5	31.5	0.03
WU-DF100L	WU-DF100L	35.5	38.0	0.04
WU-DF100LF	WU-DF100LF	41.8	44.3	0.04
WU-DF112M	WU-DF112M	45.0	48.0	0.05
WU-DF132S	WU-DF132S	68.0	71.0	0.08
WU-DF132SX	WU-DF132SX	78.1	81.1	0.08
WU-DF132M	WU-DF132M	72.5	78.5	0.08
WU-DF132MX	WU-DF132MX	82.6	88.6	0.08
WU-DF160M	WU-DF160M	121	133	0.15
WU-DF160L	WU-DF160L	133	145	0.15
WU-DF180M	WU-DF180M	162	178	0.21
WU-DF180L	WU-DF180L	177.5	193.5	0.21
WU-DF200LX	W-DF200LX	255	270	0.30
WU-DF225S	W-DF225S	320	335	0.37
WU-DF225M	W-DF225M	375	390	0.37
WU-DF250ME	W-DF250S	420	460	0.63
WU-DF280SE	W-DF250M	570	610	0.70
WU-DF280ME	W-DF280S	660	721	1.2
WU-DF315SE	W-DF280M	800	871	1.2
WU-DF315ME	W-DF315S	1000	1095	1.8
WU-DF315M	W-DF315M	1100	1195	1.8
WU-DF315L	W-DF315L	1300	1395	1.8
WU-DF355S	W-DF355S	2000	2120	2.3
WU-DF355M	W-DF355M	2300	2420	2.3
WU-DF355L	W-DF355L	2500	2620	2.3

Weights listed above are approximate and based on foot mounted (B3) standard design.

Technical information

Mechanical: grease, bearings & oilseals

Bearings and greasing arrangements

Bearings are pre-packed with a grease type dependant on frame size and re-greasing facility as detailed in table opposite:

Standard and re-greasing facilities		
Type	Standard grease	Re-greasing facility
80 - 180	EA6 Polyurea	Available
200 - 355	Esso Unirex N3	Standard

Bearing references and oil seals for horizontally-mounted motors only						
Type		Bearings ⁽¹⁾			Oil seals ⁽²⁾	
European	BS	Polarity	Drive end	Non-drive end	Drive end	Non-drive end
WU-DF80M	WU-DF80M	All	62042Z	60032Z	20 x 30 x 7 ⁽³⁾	15 x 24 x 5 ⁽³⁾
WU-DF90S/L	WU-DF90S/L	All	62052Z	62032Z	25 x 35 x 7 ⁽³⁾	17 x 28 x 6 ⁽³⁾
WU-DF100L	WU-DF100L	All	62062Z	62052Z	30 x 42 x 7 ⁽³⁾	25 x 37 x 7 ⁽³⁾
WU-DF112M	WU-DF112M	All	62062Z	62052Z	30 x 42 x 7 ⁽³⁾	25 x 37 x 7 ⁽³⁾
WU-DF132S/M	WU-DF132S/M	All	62082Z	63052Z	40 x 52 x 7 ⁽³⁾	25 x 37 x 7 ⁽³⁾
WU-DF160M/L	WU-DF160M/L	All	63092Z	63072Z	45 x 60 x 8 ⁽³⁾	35 x 47 x 7 ⁽³⁾
WU-DF180M/L	WU-DF180M/L	All	63102Z	63082Z	50 x 65 x 8 ⁽³⁾	40 x 52 x 7 ⁽³⁾
WU-DF200LX	WU-DF200LX	All	6312	6312	60 x 80 x 8 ⁽³⁾	60 x 80 x 8 ⁽³⁾
WU-DF225S	WU-DF225S	All	6313	6313	65 x 90 x 10 ⁽⁴⁾	65 x 90 x 10 ⁽⁴⁾
WU-DF225M	WU-DF225M	All	6314	6314	70 x 90 x 10 ⁽⁴⁾	70 x 90 x 10 ⁽⁴⁾
WU-DF250ME	W-DF250S	2	6314	6314	70 x 90 x 10 ⁽⁴⁾	70 x 90 x 10 ⁽⁴⁾
		4 up	6316	6316	80 x 110 x 10 ⁽³⁾	80 x 110 x 10 ⁽³⁾
WU-DF280SE	W-DF250M	2	6314	6314	70 x 90 x 10 ⁽⁴⁾	70 x 90 x 10 ⁽⁴⁾
		4 up	6318	6318	90 x 120 x 12 ⁽³⁾	90 x 120 x 12 ⁽³⁾
WU-DF280ME	W-DF280S	2	6314	6314	70 x 90 x 10 ⁽⁴⁾	70 x 90 x 10 ⁽⁴⁾
		4 up	6318	6318	90 x 120 x 12 ⁽³⁾	90 x 120 x 12 ⁽³⁾
WU-DF315SE	W-DF280M	2	6316	6316	70 x 90 x 10 ⁽⁴⁾	70 x 90 x 10 ⁽⁴⁾
		4 up	6319	6319	90 x 120 x 12 ⁽³⁾	90 x 120 x 12 ⁽³⁾
WU-DF315ME	W-DF315S	2	6316	6316	70 x 90 x 10 ⁽⁴⁾	70 x 90 x 10 ⁽⁴⁾
		4 up	6319	6319	90 x 120 x 12 ⁽³⁾	90 x 120 x 12 ⁽³⁾
WU-DF315M	W-DF315M	2	6316	6316	70 x 90 x 10 ⁽⁴⁾	70 x 90 x 10 ⁽⁴⁾
		4 up	6319	6319	90 x 120 x 12 ⁽³⁾	90 x 120 x 12 ⁽³⁾
WU-DF315L	W-DF315L	2	6316	6316	70 x 90 x 10 ⁽⁴⁾	70 x 90 x 10 ⁽⁴⁾
		4 up	6319	6319	90 x 120 x 12 ⁽³⁾	90 x 120 x 12 ⁽³⁾
WU-DF355S/M/L	W-DF355S/M/L	2	N316	6316	75 x 100 x 10 ⁽⁴⁾	75 x 100 x 10 ⁽⁴⁾
		4 up	N324	6324	115 x 145 x 14 ⁽³⁾	115 x 145 x 14 ⁽³⁾

⁽¹⁾ Frame sizes 80 and 90 have bearings with CN clearances, frame sizes 100 to 355 have bearings with C3 clearance 'medium' series

⁽²⁾ Sizes given are in mm, and represent bore x outside diameter x width
Material: ⁽³⁾ Nitrile rubber ⁽⁴⁾ Silicon rubber

Grease life expected at 80°C bearing temperature x 10 ³ hours									
Type		3000 min ⁻¹		1500 min ⁻¹		1000 min ⁻¹		750 min ⁻¹	
European	BS	Horizontal	Vertical	Horizontal	Vertical	Horizontal	Vertical	Horizontal	Vertical
WU-DF80-112	WU-DF80-112	30.0	30.0	30.0	30.0	30.0	30.0	30.0	30.0
WU-DF132	WU-DF132	30.0	25.0	30.0	30.0	30.0	30.0	30.0	30.0
WU-DF160	WU-DF160	29.0	19.0	30.0	30.0	30.0	30.0	30.0	30.0
WU-DF180	WU-DF180	24.0	16.0	30.0	30.0	30.0	30.0	30.0	30.0
WU-DF200LX	W-DF200LX	12.6	8.2	30.0	20.3	30.0	27.8	30.0	30.0
WU-DF225S	W-DF225S	12.6	8.2	30.0	20.3	30.0	27.8	30.0	30.0
WU-DF225M	W-DF225M	11.3	7.4	29.5	19.2	30.0	26.0	30.0	30.0
WU-DF250ME	W-DF250S	11.3	7.4	26.3	17.1	30.0	23.6	30.0	29.3
WU-DF280SE	W-DF250M	11.3	7.4	23.4	15.2	30.0	21.3	30.0	27.8
WU-DF280ME	W-DF280S	11.3	7.4	23.4	15.2	30.0	21.3	30.0	27.8
WU-DF315SE	W-DF280M	9.4	6.1	21.3	13.8	30.0	20.3	30.0	26.0
WU-DF315ME	W-DF315S	9.4	6.1	21.3	13.8	30.0	20.3	30.0	26.0
WU-DF315M	W-DF315M	9.4	6.1	21.3	13.8	30.0	20.3	30.0	26.0
WU-DF315L	W-DF315L	9.4	6.1	21.3	13.8	30.0	20.3	30.0	26.0
WU-DF355S/M/L ⁽¹⁾	W-DF355S/M/L ⁽¹⁾	5.0	3.3	8.2	5.3	16.2	10.5	24.5	15.9
WU-DF355S/M/L ⁽²⁾	W-DF355S/M/L ⁽²⁾	9.4	6.1	13.5	8.8	22.5	14.6	30.0	19.5

⁽¹⁾ DE = Drive End

⁽²⁾ NDE = Non-Drive End

Technical information

26

Mechanical: Axial and radial loads

Maximum permissible external axial thrust and radial loads in Newtons (N)								
Type	Poles	Horizontal shaft		Vertical shaft				Maximum permissible radial load at end of shaft (standard mounting)
		Load towards motor	Load away from motor	Shaft up		Shaft down		
				Load towards motor	Load away from motor	Load towards motor	Load away from motor	
WU-DF80M	2	912	712	746	897	946	697	775
	4	868	668	701	852	901	652	742
	6	754	554	594	734	794	534	648
	8	773	573	613	753	813	553	664
WU-DF90S	6	854	614	660	828	900	588	741
	8	874	634	680	848	920	608	757
WU-DF90L	2	1070	830	870	1041	1110	801	957
	4	1005	765	832	957	1072	717	893
	6	843	603	667	807	907	567	722
	8	870	630	686	839	926	599	749
WU-DF100L	2	1563	1243	1311	1522	1631	1202	1290
	4	1466	1146	1273	1387	1593	1067	1248
	6	1412	1092	1176	1359	1496	1039	1171
	8	1225	905	994	1167	1314	847	1022
WU-DF112M	2	1551	1231	1320	1497	1640	1177	1370
	4	1452	1132	1286	1356	1606	1036	1259
	6	1403	1083	1203	1327	1523	1007	1236
	8	1210	890	1009	1133	1329	813	1072
WU-DF132S	2	2481	2129	2283	2386	2635	2034	2184
	4	2459	2107	2330	2321	2682	1969	2133
	6	2393	2041	2217	2284	2569	1932	2032
	8	1878	1526	1728	1745	2080	1393	1614
WU-DF132M	4	2449	2097	2339	2301	2691	1949	2117
	6	2372	2020	2227	2244	2579	1892	2002
	8	1874	1522	1733	1734	2085	1382	1605
	2	2168	2663	2932	2002	2437	2202	3650
WU-DF160M	4	2153	2648	2959	1960	2464	2160	3785
	6	2022	2517	2905	1777	2410	1977	3626
	8	1509	2004	2389	1250	1894	1450	3316
	2	2144	2639	2950	1951	2455	2151	3613
WU-DF160L	4	2123	2618	2982	1895	2487	2095	3738
	6	1973	2468	2946	1669	2451	1869	3544
	8	1464	1959	2435	1144	1940	1344	3233
	2	2711	3274	3667	2465	3104	2665	4374
WU-DF180M	4	2749	3312	3830	2426	3267	2626	4556
	6	2575	3138	3785	2166	3222	2366	4334
WU-DF180L	8	2266	2829	3469	1850	2906	2050	3979

All figures are based on L10aah life of 20,000 hours

Technical information

Mechanical: Axial and radial loads

27

Maximum permissible external axial thrust and radial loads in Newtons (N)													
Type		Poles	Horizontal shaft		Vertical shaft				Maximum permissible radial load at end of shaft				
			Load towards motor	Load away from motor	Shaft up		Shaft down		Standard ball bearing		Roller bearing		
European frame	BS frame					Load towards motor	Load away from motor	Load towards motor	Load away from motor	European frame	BS frame	European frame	BS frame
WU-DF200LX	W-DF200LX	2	5435	4775	5005	5361	6021	4345	5125	5125	7541	7541	7541
		4	6058	5398	5531	6121	6781	4871	5588	5588	7541	7541	7541
		6	6055	5395	5457	6215	6875	4797	5536	5536	7541	7541	7541
		8	5781	5121	5183	5941	6601	4523	5252	5252	7541	7541	7541
WU-DF225S	W-DF225S	4	6692	6122	5941	7177	7747	5371	5963	5963	8202	8202	8202
		6	6770	6200	5935	7371	7941	5365	5982	5982	8202	8202	8202
WU-DF225M	W-DF225M	8	6441	5871	5606	7042	7612	5036	5648	5648	8202	8202	8202
		2	6729	6197	6084	7082	7614	6213	6602	6602	8745	8745	8745
		4	7530	6998	6745	8099	8631	6213	6868	6876	8921	8921	8921
		6	7640	7108	6673	8463	8995	6141	6856	6856	8921	8921	8921
WU-DF250ME	W-DF250S	8	7293	6761	6326	8116	8648	5794	6501	6501	8921	8921	8921
		2	6640	6108	5837	7209	7741	5305	6262	6262	8921	8921	8921
		4	9012	8418	8030	9794	10388	7436	8163	8163	11342	14166	14166
		6	9391	8797	8311	10311	10905	7717	8477	8477	11342	14166	14166
WU-DF280SE	W-DF250M	8	9007	8413	7927	9927	10521	7333	8087	8087	11342	14166	14166
		2	6505	5911	5472	7352	7946	4878	5692	5897	8242	8921	8921
		4	10241	9579	8943	11377	12039	8281	9260	9627	17105	14166	14166
		6	10846	10184	9423	12157	12819	8761	9336	10182	17105	14166	14166
WU-DF280ME	W-DF280S	8	10400	9738	8977	11711	12373	8315	9336	9706	17105	14166	14166
		2	6268	5736	5101	7355	7887	4569	5824	5795	9825	9503	9503
		4	9774	9112	8014	11534	12196	7352	9136	8842	17423	17348	17348
		6	10582	9920	8704	12524	13186	8042	9698	9386	17423	17348	17348
WU-DF315SE	W-DF280M	8	10136	9474	8257	12077	12739	7595	9216	8919	17423	17348	17348
		2	7443	6849	5921	8957	9551	5327	6804	6804	11342	11342	11342
		4	10305	9965	8299	12719	13059	7959	9443	9443	17414	17414	17414
		6	11190	10850	9050	13810	14150	8710	10042	10042	17414	17414	17414
WU-DF315ME	W-DF315S	8	10797	10457	8657	13417	13757	8317	9630	9630	17414	17414	17414
		2	7337	6743	5654	9082	9676	5060	6680	6680	11342	11342	11342
		4	10077	9737	7672	13044	13384	7332	9121	9121	17414	20887	20887
		6	10958	10618	8419	14131	14471	8079	9734	9734	17414	20887	20887
WU-DF315M	W-DF315M	8	10347	10007	7798	13510	13850	7458	9312	9312	17414	20887	20887
		2	7398	6804	5664	9154	9748	5070	6885	6885	11342	11342	11342
		4	10192	9852	8006	12862	13202	7666	9482	9482	17414	20748	20748
		6	11060	10720	8715	13971	14311	8375	10066	10066	17414	20748	20748
WU-DF315L	W-DF315L	8	10667	10327	8322	13578	13918	7982	9640	9640	17414	20748	20748
		2	7055	6461	5050	9164	9758	4456	6603	6606	11342	11342	11342
		4	10008	9668	7501	13123	13463	7161	9207	9207	17414	20748	20748
		6	10872	10532	8207	14229	14569	7867	9801	9801	17414	20748	20748
WU-DF355S	W-DF355S	8	10263	9923	7587	13609	13949	7247	9367	9367	17414	20748	20748
		2	6118	5524	3136	9692	10286	2542	-	-	12627	12627	12627
		4	12994	11454	8799	17389	18929	7259	-	-	27533	27533	27533
		6	14038	12498	9387	19143	20683	7847	-	-	27533	27533	27533
WU-DF355M	W-DF355M	8	14106	12566	9455	19211	20751	7915	-	-	27533	27533	27533
		2	5779	5185	2326	10050	10644	1732	-	-	12627	12627	12627
		4	12528	10988	7511	18055	19595	5971	-	-	27533	27533	27533
		6	13148	11608	7523	19533	21073	5983	-	-	27533	27533	27533
WU-DF355L	W-DF355L	8	13214	11674	7589	19599	21139	6049	-	-	27533	27533	27533
		2	5595	5001	1734	10396	10990	1140	-	-	12627	12627	12627
		4	12343	10803	7038	18282	19822	5498	-	-	27533	27533	27533
		6	12936	11396	6980	19794	21334	5440	-	-	27533	27533	27533
		8	13002	11462	7046	19860	21400	5506	-	-	27533	27533	27533

All figures are based on L10aah life of 20,000 hours

Performance data notes

DOL starting

Typical speed/current curve

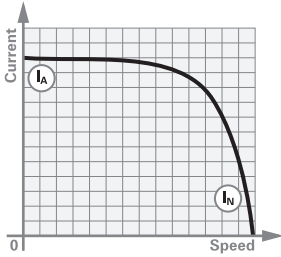

Typical speed/torque curve

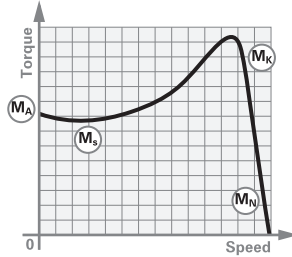

- (I_A) Starting current
- (I_N) Full load current
- (M_A) Starting torque or locked rotor torque
- (M_S) Pull up torque or run up torque
- (M_K) Pull out torque or breakdown torque
- (M_N) Full load torque

Torque/speed curves for specific motors can be supplied on request.

Star delta starting

Typical speed/current curve

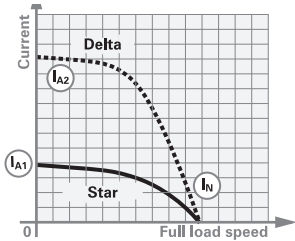

Typical speed/torque curve

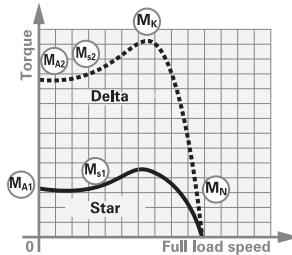

Notes

During the run up period in Star, there must be an adequate excess of motor torque over the load torque. The change to Delta must not occur until the motor is near the operating speed.

Refer to Brook Crompton for running up against a load in excess of 70% full load during Star Delta starting.

Motors are wound for either 230/400 volts or 400 / 690 volts

Performance figures are subject to IEC tolerances. Performance figures are based on a 400 volt winding.

$$J \text{ (WK}^2 \text{ or WR}^2) = \frac{GD^2}{4}$$

$$J \text{ in lb ft}^2 = \frac{\text{kgm}^2}{0.042}$$

Where performance data indicates **IE2 or IE3** 0.75kW to 375kW 2,4 & 6 pole within this catalogue, motor testing is in accordance with IEC 60034-2-1: 2007.

Dimensions notes

Page notes

Shaft		
Dim D	Tol	Limits
11 to 14	j6	+0.008 -0.003
19 to 28	j6	+0.009 -0.004
38 to 48	k6	+0.018 +0.002
55 to 80	m6	+0.030 +0.011
85 to 110	m6	+0.035 +0.013

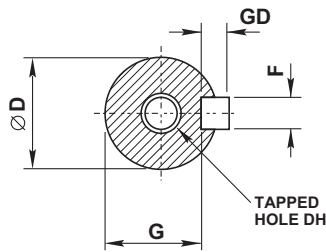

All dimensions in millimetres

Cable entry can be arranged in any one of four positions at 90° intervals

Dimensions should not be used for installation purposes unless specially endorsed

B5 mounted motors have suffix '-D' in the frame reference, eg WU-DF112MM-D and B3/B5 mounted motors have suffix '-H' in the frame reference, eg WU-DF112MM-H

B14 mounted motors have suffix 'C' in the frame reference, eg WU-DF112MM-C and B3/B14 mounted motors have suffix '-H' in the frame reference, eg WU-DF112MM-H

Dimensions should not be used for installation purposes, unless specially endorsed.

Flange		
Dim N	IEC 60072	
	Tol	Limits
110	j6	+0.013 -0.009
130	j6	+0.014 -0.011
230 to 250	j6	+0.016 -0.013
300	j6	+0.016 -0.016
350	j6	+0.018 -0.018
450	j6	+0.020 -0.020
550	j6	+0.022 -0.022
680	js6	+0.025 -0.025

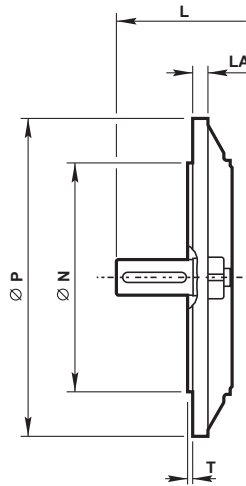

Face		
Dim N	IEC 60072	
	Tol	Limits
70 and 80	j6	+0.012 -0.007
95 and 110	j6	+0.013 -0.009
130	j6	+0.014 -0.011
230	j6	+0.016 -0.013

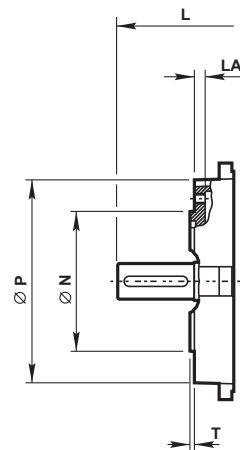

BROOK CROMPTON

Brook Crompton UK Ltd
St Thomas' Road Huddersfield
West Yorkshire HD1 3LJ UK
Tel: +44 (0) 1484 557200
Fax: +44 (0) 1484 557201
E-mail: csc@brookcrompton.com
Internet: www.brookcrompton.com

Every care has been taken to ensure the accuracy of the information contained in this publication, but, due to a policy of continuous development and improvement the right is reserved to supply products which may differ slightly from those illustrated and described in this publication



Printed in England
dh1110/**/05/13 20113E Issue 2.3 (W C.I. IE2 & IE3)
© Copyright 2013. Brook Crompton UK Ltd. All rights reserved.